

FX

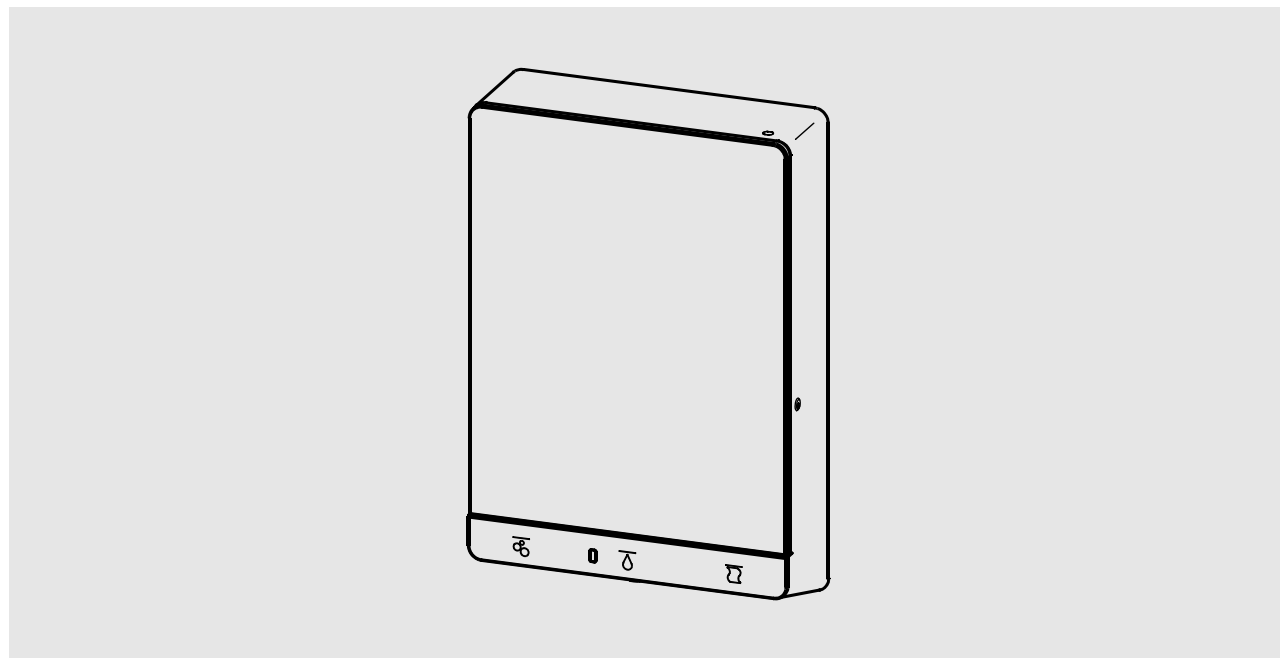

FXCT1001M

2030065018

7612982286148

DE	Montage- und Betriebsanleitung	Waschplatzeinheit
EN	Installation and operating instructions	Wash place unit
FR	Notice de montage et de mise en service	Station de lavage
ES	Instrucciones de montaje y servicio	Unidad de lavado
IT	Istruzioni per il montaggio e l'uso	Unità di lavaggio
NL	Montage- en bedrijfsinstructies	wasplaats unit
PL	Instrukcja montażu i obsługi	Moduł umywalkowy
SV	Monterings- och driftinstruktion	tvättställsenhet
CS	Návod pro montáž a provoz	Mycí jednotka
FI	Asennus- ja käyttöohje	Pesuyksikkö
RU	Инструкция по монтажу и вводу в эксплуатацию	

ZMI_001_2030065018-FXCT1001M_#SALL_#AQU_#V4_fm / 01.05.22



KWC. The new name of
Franke Water Systems

FRANKE

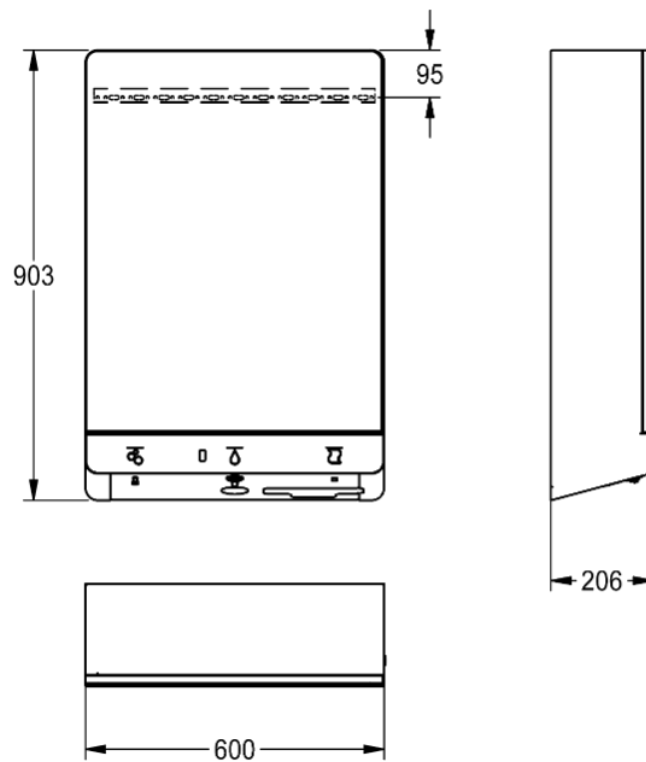
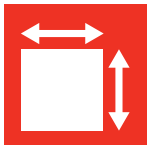
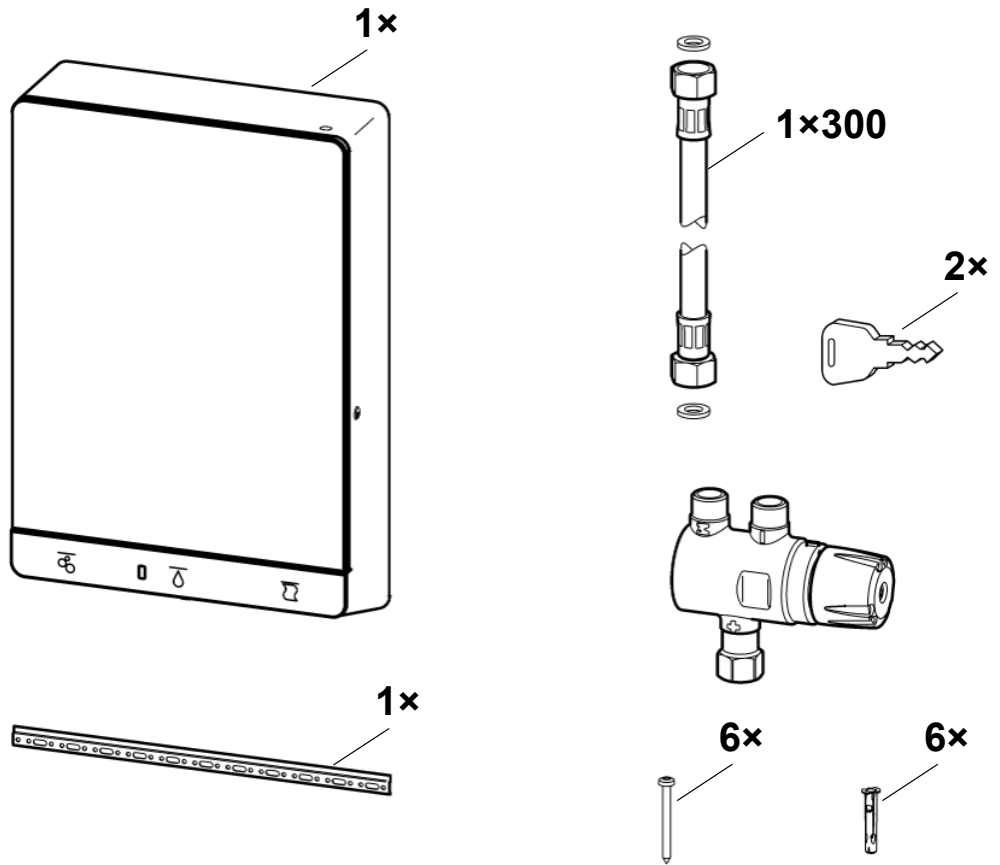

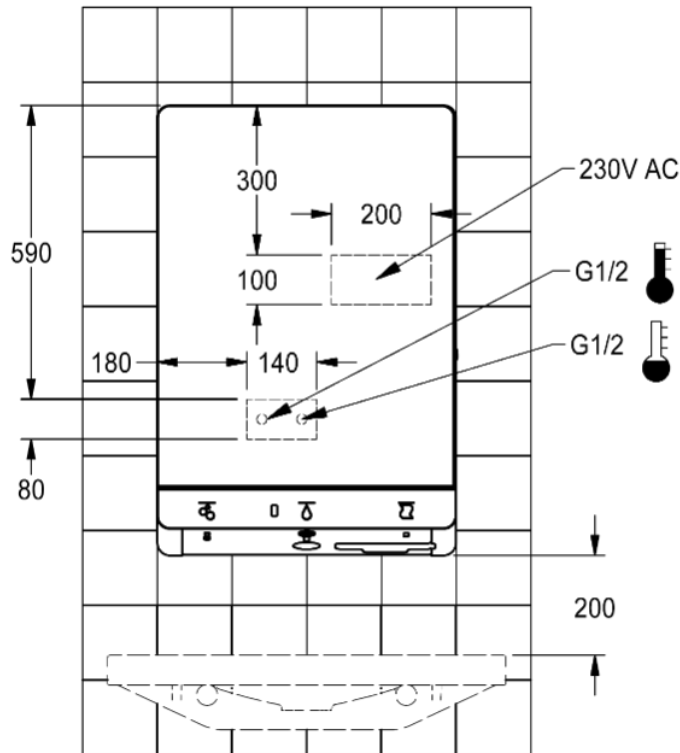

EN Installation and operating instructions

Important notes

- ▶ Installation, commissioning and maintenance are to be performed only by a qualified technician according to legal regulations provided.
- ▶ These devices can be used by children aged 8 years and above and by persons with reduced physical, sensory or mental abilities or lack of experience and/or knowledge, provided that they are being supervised or have been instructed in the safe use of the device and have understood the hazards resulting from its use. Children must not play with the device. Cleaning and user maintenance should not be performed by children.

DE Montage- und Betriebsanleitung

Wichtige Hinweise

- ▶ Montage, Inbetriebnahme und Wartung nur durch den Fachmann nach mitgelieferter Anleitung entsprechend den gesetzlichen Vorschriften.
- ▶ EU Länder: Diese Geräte können von Kindern ab 8 Jahren sowie von Personen mit reduzierten physischen, sensorischen oder mentalen Fähigkeiten oder Mangel an Erfahrung und/oder Wissen benutzt werden, wenn sie beaufsichtigt oder bezüglich des sicheren Gebrauchs des Gerätes unterwiesen wurden und die daraus resultierenden Gefahren verstanden haben. Kinder dürfen nicht mit dem Gerät spielen. Reinigung und Benutzer-Wartung dürfen nicht von Kindern durchgeführt werden.

- ▶ **Other Countrys:** These devices can be used by persons with reduced physical, sensory or mental abilities or lack of experience and/or knowledge, provided that they are being supervised or have been instructed in the safe use of the device and have understood the hazards resulting from its use. Children must not play with the device. Cleaning and user maintenance should not be performed by children.
- ▶ All technical connection regulations specified by the local water and electricity supply utility companies must be complied with.
- ▶ All work must be carried out in a de-energised state.
- ▶ Before installing flush piping system!
- ▶ After completing the installation, set the temperature limiter!
- ▶ The fitting must be operated only with original mesh filters and return flow inhibitors!
- ▶ The fitting must be checked and maintained at regular intervals depending on the water quality and in accordance with the local conditions, and rules and regulations applicable at the site.

Technical data

- ▶ Minimum flow pressure 1.0 bar (100000 Pa)
- ▶ Maximum operating pressure 10 bar (1000000 Pa)
- ▶ Recommended flow pressure 3 bar (300000 Pa)
- ▶ Volume flow 6 l/min
- ▶ Operating voltage 230 V AC; 50/60 Hz
- ▶ Power overall 100 W
- ▶ Type of protection IPX1

Warning

- ▶ Include the device in the list of electrical equipment destined for periodic checking.
- ▶ Before opening the device, disconnect it from the mains supply.
- ▶ Failure to observe can mean risk of death or material damage, e.g. from electric shock or fire.
- ▶ The supply line must have a cut-off device, e.g. a disconnectable circuit breaker or a screw-type fuse.

- ▶ **Andere Länder:** Diese Geräte können von Personen mit reduzierten physischen, sensorischen oder mentalen Fähigkeiten oder Mangel an Erfahrung und/oder Wissen benutzt werden, wenn sie beaufsichtigt oder bezüglich des sicheren Gebrauchs des Gerätes unterwiesen wurden und die daraus resultierenden Gefahren verstanden haben. Kinder dürfen nicht mit dem Gerät spielen. Reinigung und Benutzer-Wartung dürfen nicht von Kindern durchgeführt werden.
- ▶ Die technischen Anschlussbedingungen der örtlichen Wasser- und Energieversorgungsunternehmen einhalten.
- ▶ Alle Arbeiten im spannungsfreien Zustand durchführen.
- ▶ Vor Installation Rohrleitungen spülen!
- ▶ Nach erfolgter Montage die Temperaturbegrenzung einstellen!
- ▶ Armatur nur mit original Sieben und Rückflussverhinderern betreiben!
- ▶ In Abhängigkeit von der Wasserqualität, den örtlichen Gegebenheiten und den vor Ort geltenden Bestimmungen die Armatur in regelmäßigen Abständen prüfen und warten.

Technische Daten

- ▶ Mindestfließdruck 1,0 bar (100000 Pa)
- ▶ Maximaler Betriebsdruck 10 bar (1000000 Pa)
- ▶ Empfohlener Fließdruck 3 bar (300000 Pa)
- ▶ Volumenstrom 6 l/min
- ▶ Anschlussspannung 230 V AC; 50/60 Hz
- ▶ Leistung gesamt 100 W
- ▶ Schutzart IPX1

Warnung

- ▶ Das Gerät in die intervallmäßige Überprüfung der Elektrogeräte aufnehmen.
- ▶ Das Gerät vor dem Öffnen und bei Reinigungsarbeiten vom Netz trennen.
- ▶ Nichtbeachtung kann Lebensgefahr oder Sachschäden bewirken, z. B. durch elektrischen Schlag oder Feuer.
- ▶ Die Zuleitung muss eine Abschaltvorrichtung besitzen, z.B. einen abschaltbaren Sicherungsautomat oder eine Schraubsicherung.

- ▶ Connect the unit to an electrical supply line with a residual current circuit breaker.
- ▶ Do not connect any further consumers to the electrical supply line of the unit.
- ▶ Only new hose sets supplied with the device may be used for connection to the water supply. Old hose sets may not be reused.

PL Instrukcja montażu i obsługi

Ważne wskazówki

- ▶ Montaż, uruchomienie i konserwacja muszą być przeprowadzone przez specjalistę zgodnie z dostarczoną instrukcją i regulacjami prawnymi.
- ▶ Kraje UE: Urządzenia mogą być używane przez dzieci, które ukończyły 8 lat i przez osoby o ograniczonych zdolnościach fizycznych, czuciowych lub mentalnych lub nieposiadające doświadczenia i/lub wiedzy w tym zakresie pod warunkiem, że zostały poinformowane o zasadach bezpiecznego korzystania z urządzenia i zrozumiały wynikające z tego zagrożenia. Urządzenie nie służy do zabawy. Czyszczenia i konserwacji nie mogą wykonywać dzieci.
- ▶ Inne kraje: Urządzenia mogą być używane przez osoby o ograniczonych zdolnościach fizycznych, czuciowych lub mentalnych lub nieposiadające doświadczenia i/lub wiedzy w tym zakresie pod warunkiem, że zostały poinformowane o zasadach bezpiecznego korzystania z urządzenia i zrozumiały wynikające z tego zagrożenia. Urządzenie nie służy do zabawy. Czyszczenia i konserwacji nie mogą wykonywać dzieci.
- ▶ Należy przestrzegać technicznych warunków podłączenia lokalnych zakładów wodociągowych i energetycznych.
- ▶ Wszystkie prace przeprowadzać po odłączeniu zasilania elektrycznego.
- ▶ Przed instalacją przepłukać rury!
- ▶ Po zakończeniu montażu ustawić ograniczenie temperatury!
- ▶ Armatury należy używać wyłącznie z oryginalnymi sitkami i zaworami zwrotnymi!
- ▶ Armaturę należy poddawać regularnej kontroli i konserwacji w zależności od jakości wody, warunków lokalnych i obowiązujących przepisów.

- ▶ Gerät an eine elektrische Zuleitung mit Fehlerstrom-Schutzschalter anschließen.
- ▶ Keine weiteren Verbraucher an die elektrische Zuleitung des Geräts anschließen.
- ▶ Es dürfen, zum Anschluß an die Wasserversorgung, nur neue Schlauchsets, die mit dem Gerät geliefert werden, benutzt werden. Alte Schlauchsets dürfen nicht wiederverwendet werden.

SV Monterings- och driftinstruktion

Viktiga informationer

- ▶ Montering, idrifttagning och underhåll får endast utföras av fackfolk. Arbetsena ska utföras enligt medföljande anvisningar och i enlighet med gällande lagar och bestämmelser.
- ▶ EU -länder: Dessa enheter kan användas av barn från 8 års ålder liksom av personer med nedsatt fysisk, sensorisk eller mental förmåga eller med bristande erfarenhet och/eller kunskap, om de övervakats eller undervisats om enhetens säkra användning och förstått de risker som finns. Barn får inte leka med enheten. Rengöring och användarunderhåll får inte utföras av barn.
- ▶ Andra länder: Dessa enheter kan användas av personer med nedsatt fysisk, sensorisk eller mental förmåga eller med bristande erfarenhet och/eller kunskap, om de övervakats eller undervisats om enhetens säkra användning och förstått de risker som finns. Barn får inte leka med enheten. Rengöring och användarunderhåll får inte utföras av barn.
- ▶ Beakta anslutningsvillkoren från lokala vatten- och energiverk.
- ▶ Genomför alla arbeten i spänningslöst tillstånd.
- ▶ Spola igenom rörledningarna före installation!
- ▶ När monteringen har gjorts skall temperaturbegränsningen ställas in!
- ▶ Använd armaturen endast med originalsilar och originalåterflödesförhindrare!
- ▶ Kontrollera och serva armaturen med intervaller som bestäms av vattenkvaliteten samt de lokala förhållandena och de bestämmelser som gäller där.

Dane techniczne

- ▶ Minimalne ciśnienie przepływu 1,0 bar (100000 Pa)
- ▶ Maksymalne ciśnienie robocze 10 barów (1000000 Pa)
- ▶ Zalecane ciśnienie przepływu 3 barów (300000 Pa)
- ▶ Objętościowe natężenie przepływu 6 l/min
- ▶ Napięcie przyłączeniowe 230 V AC; 50/60 Hz
- ▶ Wydajność łączna 100 W
- ▶ Rodzaj ochrony IPX1

Ostrzeżenie

- ▶ Urządzenie należy poddawać okresowej kontroli dla urządzeń elektrycznych.
- ▶ Przed otwarciem urządzenie odłączyć od sieci.
- ▶ Nieprzestrzeganie tej zasady może stwarzać zagrożenie utraty życia i powstania strat materialnych, spowodowanych np. przez porażenie prądem lub pożar.
- ▶ Przewód zasilający musi być wyposażony w urządzenie odłączające, np. odłączany bezpiecznik samoczynny lub bezpiecznik wkręcany.
- ▶ Podłączyć urządzenie do przewodu zasilającego wyposażonego w wyłącznik różnicowoprądowy.
- ▶ Nie należy podłączać żadnych innych odbiorników do przewodu zasilającego urządzenie.
- ▶ Do podłączania do dopływu wody można używać wyłącznie nowych zestawów węży dostarczonych z urządzeniem. Starych zestawów węży nie można wykorzystywać ponownie.

Tekniska data

- ▶ Minsta hydrauliska tryck 1,0 bar (100000 Pa)
- ▶ Maximalt driftryck 10 bar (1000000 Pa)
- ▶ Rekommenderat hydrauliskt tryck 3 bar (300000 Pa)
- ▶ Volymström 6 l/min
- ▶ Skyddsklass 230 V AC; 50/60 Hz
- ▶ Total effekt 100 W
- ▶ Skyddsklass IPX1

Viktiga informationer

- ▶ Ta upp apparaten i de regelbundna kontrollerna av elapparater.
- ▶ Bryt strömmen till apparaten innan den öppnas.
- ▶ Om detta inte beaktas kan det leda till livsfarliga situationer eller saksador, t.ex. genom elstötar eller brand.
- ▶ Tilloppsledningen ska ha en avstängningsanordning, t.ex. en fråkopplingsbar automatsäkring eller en skruvsäkring.
- ▶ Anslut enheten till en elektrisk tilloppsledning med jordfelsbrytare.
- ▶ Inga andra förbrukare får anslutas till enhetens elektriska tilloppsledning.
- ▶ Endast nya slanguppsättningar som medföljer apparaten får användas för anslutning till vattenförsörjningen. Gamla slanguppsättningar får inte återanvändas.

Remarques importantes

- ▶ Le montage, la mise en service et la maintenance doivent uniquement être effectués par un spécialiste conformément au mode d'emploi livré et selon les règlements en vigueur.
- ▶ Pays de l'UE: Ces appareils peuvent être utilisés par des enfants à partir de l'âge de huit ans ainsi que par des personnes souffrant d'un handicap physique, sensoriel ou mental ou manquant d'expérience et/ou n'ayant pas les connaissances nécessaires si elles sont encadrées ou si elles ont appris à utiliser les appareils de manière sûre et si elles ont compris les risques en résultant. Les enfants n'ont pas le droit de jouer avec les appareils. Les travaux de nettoyage et d'entretien ne peuvent pas être effectués par des enfants.
- ▶ Autres pays: Ces appareils peuvent être utilisés par des personnes souffrant d'un handicap physique, sensoriel ou mental ou manquant d'expérience et/ou n'ayant pas les connaissances nécessaires si elles sont encadrées ou si elles ont appris à utiliser les appareils de manière sûre et si elles ont compris les risques en résultant. Les enfants n'ont pas le droit de jouer avec les appareils. Les travaux de nettoyage et d'entretien ne peuvent pas être effectués par des enfants.
- ▶ Observer les conditions techniques de raccordement des entreprises locales de distribution d'eau et d'énergie.
- ▶ Effectuez tous les travaux quand le dispositif est hors tension.
- ▶ Rincer les conduites avant d'installer !
- ▶ Une fois le montage terminé, régler la limitation de température !
- ▶ Ne faire fonctionner la robinetterie qu'avec les filtres et clapets de non retour d'origine !
- ▶ En fonction de la qualité de l'eau, ainsi que des conditions et des dispositions locales, il convient de contrôler et d'entretenir la robinetterie à intervalles réguliers.

Důležité pokyny

- ▶ Montáž, uvedení do provozu a údržbu smí provádět pouze odborník podle příloženého návodu a při dodržení zákonných předpisů.
- ▶ Země EU: Tato zařízení smějí používat děti starší 8 let a osoby se sníženou fyzickou, smyslovou nebo duševní schopností nebo osoby s nedostatkem zkušeností anebo znalostí pouze pod dohledem nebo poté, co byly poučeny o bezpečném použití zařízení a rozumějí nebezpečím, která mohou vzniknout při nedodržení pokynů k bezpečnému použití. Děti si nesmějí se zařízeními hrát. Děti nesmějí provádět čištění ani uživatelskou údržbu.
- ▶ Ostatní země: Tato zařízení smějí používat osoby se sníženou fyzickou, smyslovou nebo duševní schopností nebo osoby s nedostatkem zkušeností anebo znalostí pouze pod dohledem nebo poté, co byly poučeny o bezpečném použití zařízení a rozumějí nebezpečím, která mohou vzniknout při nedodržení pokynů k bezpečnému použití. Děti si nesmějí se zařízeními hrát. Děti nesmějí provádět čištění ani uživatelskou údržbu.
- ▶ Dodržujte podmínky připojení stanovené místním dodavatelem vody a elektrické energie.
- ▶ Veškeré práce vykonávejte ve stavu bez napětí.
- ▶ Před instalací potrubí propláchněte!
- ▶ Po provedené montáži nastavit omezení teploty!
- ▶ Provozovat armaturu jen s originálními sítky a zařízeními proti zpětnému toku!
- ▶ V závislosti na kvalitě vody, místních podmínkách a předpisech platných v místě instalace je nutné provádět v pravidelných intervalech kontrolu a údržbu armatury.

Données techniques

- ▶ Pression dynamique minimale 1,0 bar (100000 Pa)
- ▶ Pression de service maximale 10 bars (1000000 Pa)
- ▶ Pression dynamique recommandée 3 bars (300000 Pa)
- ▶ Débit volumique 6 l/min
- ▶ Tension de raccordement 230 V AC; 50/60 Hz
- ▶ Puissance totale 100 W
- ▶ Type de protection IPX1

Avertissement

- ▶ L'appareil doit être compris dans le contrôle régulier des appareils électriques.
- ▶ Débrancher l'appareil avant de l'ouvrir.
- ▶ Le non respect des consignes peut entraîner un danger mortel ou des blessures corporelles (choc électrique ou incendie par exemple).
- ▶ Le câble d'alimentation doit posséder un dispositif de coupure, par ex. un disjoncteur automatique ou un fusible à visser.
- ▶ Raccorder l'appareil à un câble d'alimentation électrique équipé d'un disjoncteur différentiel.
- ▶ Ne raccorder aucun autre consommateur sur le câble d'alimentation de l'appareil.
- ▶ Utiliser exclusivement des kits de flexibles neufs livrés avec l'appareil pour raccorder l'alimentation en eau. Ne pas réutiliser des kits de flexibles usagés.

Technické údaje

- ▶ Minimální průtočný tlak 1,0 bar (100000 Pa)
- ▶ Maximální provozní tlak 10 bar (1000000 Pa)
- ▶ Doporučený průtočný tlak 3 bar (300000 Pa)
- ▶ Průtok 6 l/min
- ▶ Přípojné napětí 230 V AC; 50/60 Hz
- ▶ Celkový příkon 100 W
- ▶ Krytí IPX1

Varování

- ▶ Zařadte přístroj do periodického přezkušování elektrických zařízení.
- ▶ Před otevřením přístroje jej odpojte od elektrické sítě.
- ▶ Nedodržení tohoto pokynu může mít za následek ohrožení života nebo materiální škody, např. v důsledku zasažení elektrickým proudem nebo požáru.
- ▶ Na přívodním vedení musí být vypínací zařízení, např. vypínatelný pojistkový automat nebo šroubová pojistka.
- ▶ Přístroj připojte k elektrickému přívodnímu kabelu s proudovým chráničem.
- ▶ K elektrickému přívodnímu kabelu přístroje nepřipojujte žádné další spotřebiče.
- ▶ K připojení k přívodu vody smí být použity pouze nové sady hadic, které jsou dodány s přístrojem. Nesmíte znovu použít staré sady hadic.

Indicaciones importantes

- ▶ El montaje, la puesta en servicio y el mantenimiento, solamente deben ser llevados a cabo por un técnico especializado según las instrucciones que se adjuntan, observando las prescripciones legales.
- ▶ Países de la UE: Estos aparatos solo pueden ser utilizados por niños mayores de 8 años, o por personas que padezcan una discapacidad física, sensorial o mental o carezcan de experiencia o conocimientos, si se encuentran bajo vigilancia, han sido instruidos debidamente sobre el uso seguro del aparato y han entendido los peligros que dicho uso puede entrañar. Los niños no pueden jugar con este aparato. Las operaciones de limpieza y mantenimiento no deben correr a cargo de niños.
- ▶ Otros países: Estos aparatos solo pueden ser utilizados por personas que padezcan una discapacidad física, sensorial o mental o carezcan de experiencia o conocimientos, si se encuentran bajo vigilancia, han sido instruidos debidamente sobre el uso seguro del aparato y han entendido los peligros que dicho uso puede entrañar. Los niños no pueden jugar con este aparato. Las operaciones de limpieza y mantenimiento no deben correr a cargo de niños.
- ▶ Se han de cumplir las condiciones técnicas de conexión de las empresas locales de suministro de agua y energía.
- ▶ Todos los trabajos deben realizarse con la tensión de alimentación desconectada.
- ▶ ¡Enjuagar las tuberías antes de instalar!
- ▶ ¡Ajuste el límite de temperatura tras realizar el montaje!
- ▶ ¡La grifería debe hacerse funcionar únicamente con los tamices y las válvulas antiretorno originales!
- ▶ En función de la calidad del agua, las condiciones locales y la legislación vigente, realizar las inspecciones y el mantenimiento de la grifería a intervalos regulares.

Tärkeitä ohjeita

- ▶ Asennuksen, käyttöönoton ja huollon saa suorittaa vain alan ammattilainen mukana toimitettujen ohjeiden mukaisesti ja lakisääteisiä määräyksiä noudattaen.
- ▶ EU -maat: Laitetta eivät voi ilman ohjausta ja valvontaa käyttää alle 8-vuotiaat lapset tai vanhemmat henkilöt, joiden fyysiset, sensoriset tai henkiset ominaisuudet ovat heikentyneet tai joilla ei ole riittäviä kokemuksia ja/tai tietoja laitteen käytöstä ja siihen sisältyvistä riskeistä. Lasten ei saa antaa leikkiä laitteella. Lasten ei saa antaa suorittaa laitteen puhdistusta tai muuta huoltoa.
- ▶ Muut maat: Laitetta eivät voi ilman ohjausta ja valvontaa käyttää vanhemmat henkilöt, joiden fyysiset, sensoriset tai henkiset ominaisuudet ovat heikentyneet tai joilla ei ole riittäviä kokemuksia ja/tai tietoja laitteen käytöstä ja siihen sisältyvistä riskeistä. Lasten ei saa antaa leikkiä laitteella. Lasten ei saa antaa suorittaa laitteen puhdistusta tai muuta huoltoa.
- ▶ Paikallisten vesi- ja energiahuoltoyritysten teknisiä liitântäehtoja on noudatettava.
- ▶ Kaikki työt on tehtävä jännitteettömälle järjestelmälle.
- ▶ Huuhtelee putkijohdot ennen asennusta!
- ▶ Säädä asennuksen jälkeen lämpötilan rajoitus!
- ▶ Käytä varusteet vain alkuperäisten sihtien ja takaisinvirtauksen eston kanssa!
- ▶ Hana tulee tarkistaa ja huoltaa säännöllisin väliajoin veden laadusta, paikallisista oloista ja paikalla voimassa olevista määräyksistä riippuen.

Datos técnicos

- ▶ Presión mínima de flujo 1,0 bar (100000 Pa)
- ▶ Presión máxima de servicio 10 bares (1000000 Pa)
- ▶ Presión de flujo recomendada 3 bares (300000 Pa)
- ▶ Flujo volumétrico 6 l/min
- ▶ Tensión de conexión 230 V AC; 50/60 Hz
- ▶ Rendimiento total 100 W
- ▶ Modo de protección IPX1

Aviso

- ▶ Incluir el aparato en las comprobaciones periódicas de los aparatos eléctricos
- ▶ Desenchufar el aparato de la red antes de abrirlo.
- ▶ En caso de no observación existe el riesgo de peligro mortal o de que se produzcan daños materiales, por ejemplo, por causa de electrocución o fuego.
- ▶ El cable de alimentación debe contar con un disposición de desconexión, p. ej., un fusible automático o un fusible de rosca.
- ▶ Conectar el equipo a un cable de alimentación eléctrica con un interruptor diferencial.
- ▶ No conectar otros consumidores al cable de alimentación eléctrica del equipo.
- ▶ Para la conexión al suministro de agua, deben utilizarse exclusivamente juegos de tubos nuevos suministrados junto con el equipo. No está permitido reutilizar los juegos de tubos ya usados.

Tekniset tiedot

- ▶ Vähimmäisvirtauspaine 1,0 bar (100000 Pa)
- ▶ Suurin käyttöpainne 10 bar (1000000 Pa)
- ▶ Suositeltava virtauspaine 3 bar (300000 Pa)
- ▶ Tilavuusvirta 6 l/min
- ▶ Verkkojännite 230 V AC; 50/60 Hz
- ▶ Teho yhteensä 100 W
- ▶ Suojaustapa IPX1

Varoitus

- ▶ Laitte on tarkistettava säännöllisin väliajoin muiden sähkölaitteiden tavoin.
- ▶ Ennen laitteen avaamista laite on irrotettava sähköverkosta.
- ▶ Ohjeiden laiminlyöminen voi johtaa hengenvaaraan tai aineellisiin vahinkoihin esim. sähköiskun tai tulipalon vuoksi.
- ▶ Tulojohdossa on oltava sammutuslaite, esim. sammutettava sulakeautomaatti tai kiertovarmistus.
- ▶ Laitte liitetään sähköiseen tulojohtoon vikavirtasuojakytkimellä.
- ▶ Älä liitä laitteen sähköiseen tulojohtoon mitään muita kuluttajia.
- ▶ Vesijohtoverkkoon liittämiseen saa käyttää vain uutta, laitteen mukana toimitettua letkusetettä. Vanhoja letkusetettä ei saa käyttää uudelleen.

IT

Istruzioni per il montaggio e l'uso

Avvertenze importanti

- ▶ Montaggio, messa in esercizio e manutenzione solo da parte di un tecnico specializzato conformemente alle istruzioni fornite e nel rispetto delle disposizioni legislative.
- ▶ Paesi dell'UE: Questi apparecchi possono essere utilizzati da bambini a partire dagli 8 anni e da persone con ridotte capacità fisiche, sensoriali o mentali oppure con mancanza di esperienza e di conoscenza se si trovano sotto adeguata sorveglianza oppure se sono stati istruiti circa l'uso sicuro dell'apparecchio e se ne hanno compreso i pericoli connessi. I bambini non devono giocare con l'apparecchio. Pulizia e manutenzione non devono essere eseguite da bambini.
- ▶ Altri paesi: Questi apparecchi possono essere utilizzati da persone con ridotte capacità fisiche, sensoriali o mentali oppure con mancanza di esperienza e di conoscenza se si trovano sotto adeguata sorveglianza oppure se sono stati istruiti circa l'uso sicuro dell'apparecchio e se ne hanno compreso i pericoli connessi. I bambini non devono giocare con l'apparecchio. Pulizia e manutenzione non devono essere eseguite da bambini.
- ▶ Rispettare le condizioni tecniche di allacciamento delle società locali di erogazione di energia elettrica e di approvvigionamento idrico.
- ▶ Eseguire tutti i lavori fuori tensione.
- ▶ Sciacquare le tubazioni prima di installare!
- ▶ Una volta terminata l'installazione, impostare la limitazione di temperatura!
- ▶ Utilizzare la rubinetteria esclusivamente con i filtri e le valvole antiriflusso originali!
- ▶ Controllare e sottoporre a manutenzione l'apparecchio ad intervalli regolari, in funzione della qualità dell'acqua, delle caratteristiche locali e delle vigenti disposizioni locali.

RU

Инструкция по монтажу и вводу в эксплуатацию

Важные указания

- ▶ Монтаж, ввод в эксплуатацию и техническое обслуживание осуществляется только специалистами в соответствии с приложенной инструкцией согласно правовым нормам.
- ▶ Страны ЕС: Данными приборами могут пользоваться дети с 8 лет, а также лица с ограниченными физическими, тактильными или умственными способностями либо без достаточного опыта и/или знаний, если они находятся под присмотром или были проинструктированы о безопасном пользовании прибором и поняли исходящую от него опасность. Играть с прибором детям запрещено. Поручать чистку и пользовательское техническое обслуживание детям запрещено.
- ▶ Другие страны: Данными приборами могут пользоваться лица с ограниченными физическими, тактильными или умственными способностями либо без достаточного опыта и/или знаний, если они находятся под присмотром или были проинструктированы о безопасном пользовании прибором и поняли исходящую от него опасность. Играть с прибором детям запрещено. Поручать чистку и пользовательское техническое обслуживание детям запрещено.
- ▶ Соблюдайте технические условия подключения местных водо- и энергообеспечивающих предприятий.
- ▶ Выполняйте все работы при отключенном напряжении.
- ▶ Перед инсталляцией промыть трубки!
- ▶ После монтажа отрегулировать температурный предел!
- ▶ Эксплуатировать арматуру только с оригинальными фильтрами и клапанами обратного течения!
- ▶ Арматуру необходимо регулярно чистить и обслуживать в зависимости от качества воды, местных условий и действующих в месте эксплуатации предписаний.

Specifiche tecniche

- ▶ Pressione idraulica min. 1,0 bar (100000 Pa)
- ▶ Pressione di esercizio max. 10 bar (1000000 Pa)
- ▶ Pressione idraulica consigliata 3 bar (300000 Pa)
- ▶ Portata volumetrica 6 l/min
- ▶ Pressione di allacciamento 230 V AC; 50/60 Hz
- ▶ Potenza totale 100 W
- ▶ Tipo di protezione IPX1

Avvertenza

- ▶ Includere l'apparecchio nel controllo periodico degli apparecchi elettrici.
- ▶ Sconnettere l'apparecchio dalla rete prima di aprirlo.
- ▶ La non osservanza può causare pericolo per la vita o danni materiali, dovuti ad es. a scosse elettriche o incendio.
- ▶ La linea di alimentazione deve essere provvista di un dispositivo di spegnimento, ad es. un interruttore automatico disinseribile o un fusibile a vite.
- ▶ Collegare l'apparecchio ad una linea di alimentazione elettrica con interruttore differenziale.
- ▶ Non collegare altre utenze alla linea di alimentazione elettrica dell'apparecchio.
- ▶ Per il collegamento all'alimentazione idrica usare solo le serie di flessibili nuovi consegnate con l'apparecchio. Non riutilizzare le vecchie serie di flessibili.

Технические характеристики

- ▶ Минимальный гидравлический напор 1,0 бар (100000 Па)
- ▶ Максимальное рабочее давление 10 бар (1000000 Па)
- ▶ Рекомендуемый гидравлический напор 3 бар (300000 Па)
- ▶ Объемный расход 6 л/мин
- ▶ Напряжение питающей сети 230 В переменного тока; 50/60 Hz
- ▶ Общая мощность 100 Вт
- ▶ Количество воздуха IPX1

Предупреждение

- ▶ Принятие прибора на регулярную проверку электроприборов.
- ▶ Перед открытием отсоедините прибор от электросети.
- ▶ Несоблюдение требований может повлечь за собой возникновение угрозы для жизни или нанесения ущерба, напр., вследствие удара электротоком или пожара.
- ▶ Подводящая линия должна быть оснащена отключающим устройством, например защитным автоматом с возможностью отключения или ввинчиваемым предохранителем.
- ▶ Подключить устройство к линии электропитания с устройством защитного отключения.
- ▶ Не подключать дополнительные потребители к линии электропитания устройства.
- ▶ Для подвода воды разрешается использовать только новые комплекты шлангов, поставляемые вместе с устройством. Не использовать повторно старые комплекты шлангов.

Belangrijke aanwijzingen

- ▶ Montage, inbedrijfstelling en onderhoud mogen alleen door een vakman volgens de meegeleverde instructies in overeenstemming met de wettelijke voorschriften worden uitgevoerd.
- ▶ EU-landen: Dit apparaat kan door kinderen vanaf 8 jaar oud, evenals door personen met verminderde fysieke, sensorische of geestelijke vaardigheden of een tekort aan ervaring en/of kennis worden gebruikt, indien zij onder toezicht staan of over het gebruik van het apparaat zijn geïnstrueerd en de daaruit resulterende gevaren hebben begrepen. Kinderen mogen niet met het apparaat spelen. Reiniging en onderhoud mag niet door kinderen worden uitgevoerd.
- ▶ Andere landen: Dit apparaat kan door personen met verminderde fysieke, sensorische of geestelijke vaardigheden of een tekort aan ervaring en/of kennis worden gebruikt, indien zij onder toezicht staan of over het gebruik van het apparaat zijn geïnstrueerd en de daaruit resulterende gevaren hebben begrepen. Kinderen mogen niet met het apparaat spelen. Reiniging en onderhoud mag niet door kinderen worden uitgevoerd.
- ▶ De technische voorwaarden voor aansluiting van de plaatselijke water- en energiemaatschappijen moeten in acht worden genomen.
- ▶ Armatuur alleen met originele zeven en terugstroomkleppen gebruiken!
- ▶ Afhankelijk van de waterkwaliteit, de plaatselijke omstandigheden en de plaatselijke voorschriften de armatuur regelmatig controleren en onderhouden.

Technische gegevens

- ▶ Minimale dynamische druk 1,0 bar (100000 Pa)
- ▶ Maximale werkdruk 10 bar (1000000 Pa)
- ▶ Aanbevolen dynamische druk 3 bar (300000 Pa)
- ▶ Volumestroom 6 l/min
- ▶ Aansluitspanning 230 V AC; 50/60 Hz
- ▶ Vermogen in totaal 100 W
- ▶ Veiligheidsgraad IPX1

Waarschuwing

- ▶ Apparaat opnemen in de regelmatige controle van de elektrische apparatuur.
- ▶ Apparaat alvorens te openen van het net scheiden.
- ▶ Veronachtzaming kan tot levensgevaar of materiële schade leiden, bijv. door elektrische schok of brand.
- ▶ De toevoerleiding moet een uitschakelvoorziening hebben, bijv. een uitschakelbare zekeringsautomaat of een schroefzekering.
- ▶ Apparaat aan een elektrische toevoerleiding met aardlekschakelaar aansluiten.
- ▶ Geen andere verbruikers aan de elektrische toevoerleiding van het apparaat aansluiten.
- ▶ Voor de aansluiting op de watertoevoer mag alleen gebruik worden gemaakt van de nieuwe slangensets die met het apparaat worden geleverd. Oude slangensets mogen niet opnieuw worden gebruikt.

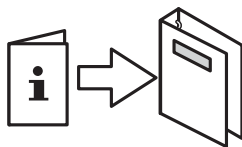
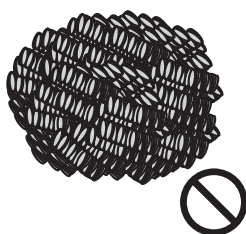
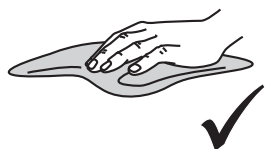

1. Montage

EN Installation
FR Montage
ES Montaje
IT Montaggio

NL Montage
PL Montaż
SV Montering

CS Montáž
FI Asennus
RU Монтаж

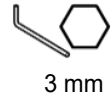
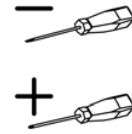
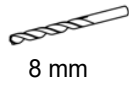

1

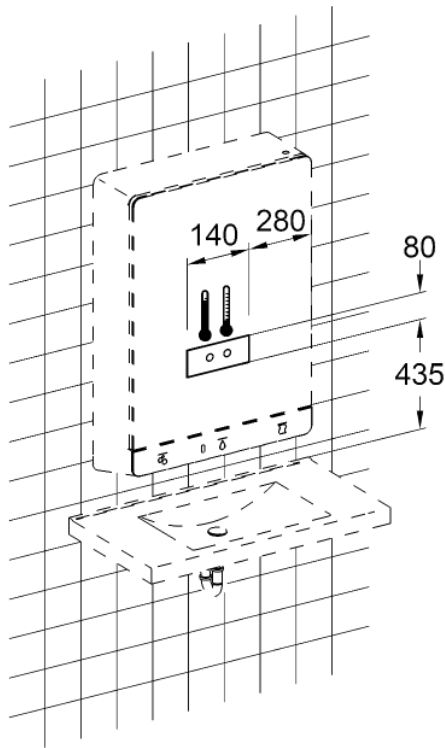

2

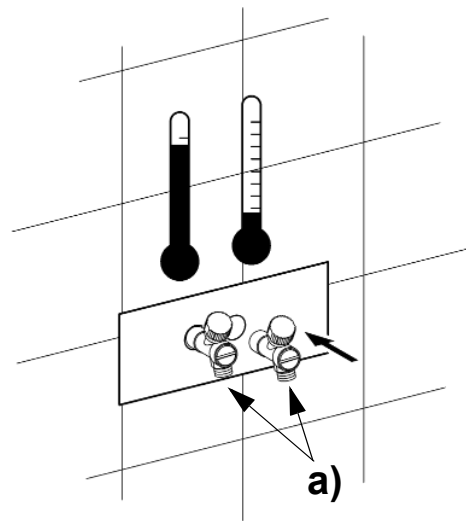

EN a) Not included in scope of delivery

DE a) nicht Lieferumfang

PL a) poza zakresem dostawy

SV a) ngår ej i leveransen

FR a) non compris dans la livraison

CS a) Není součástí dodávky

ES a) no forma parte del volumen de suministro

FI a) ei kuulu toimitukseen

IT a) Non compreso nella fornitura

RU a) Не входит в объём поставки

NL a) niet bij levering inbegrepen

3

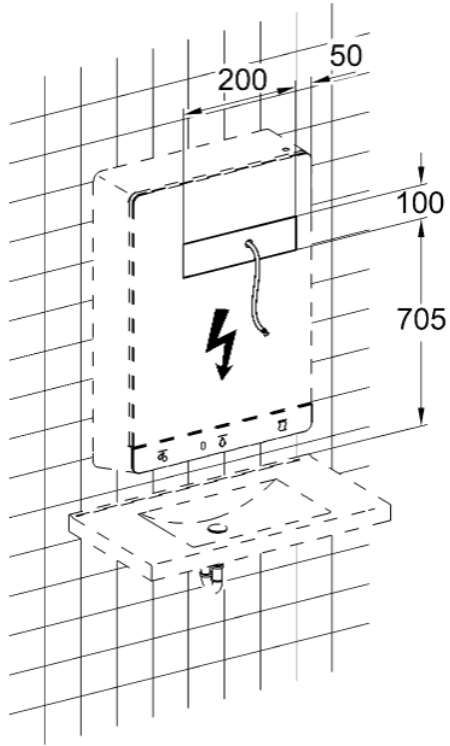

4

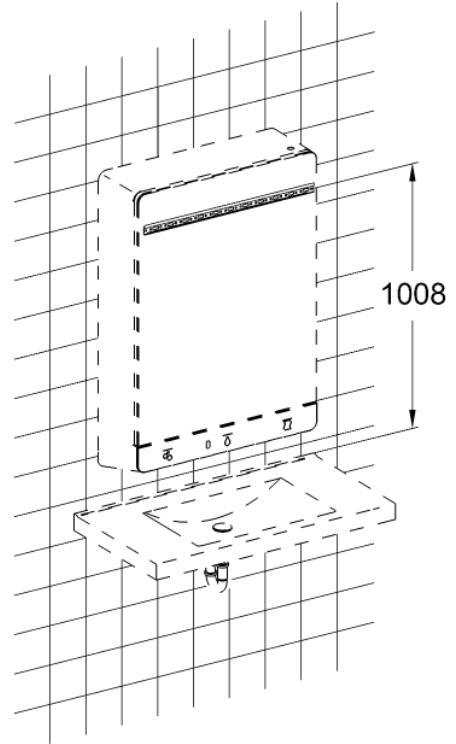

5

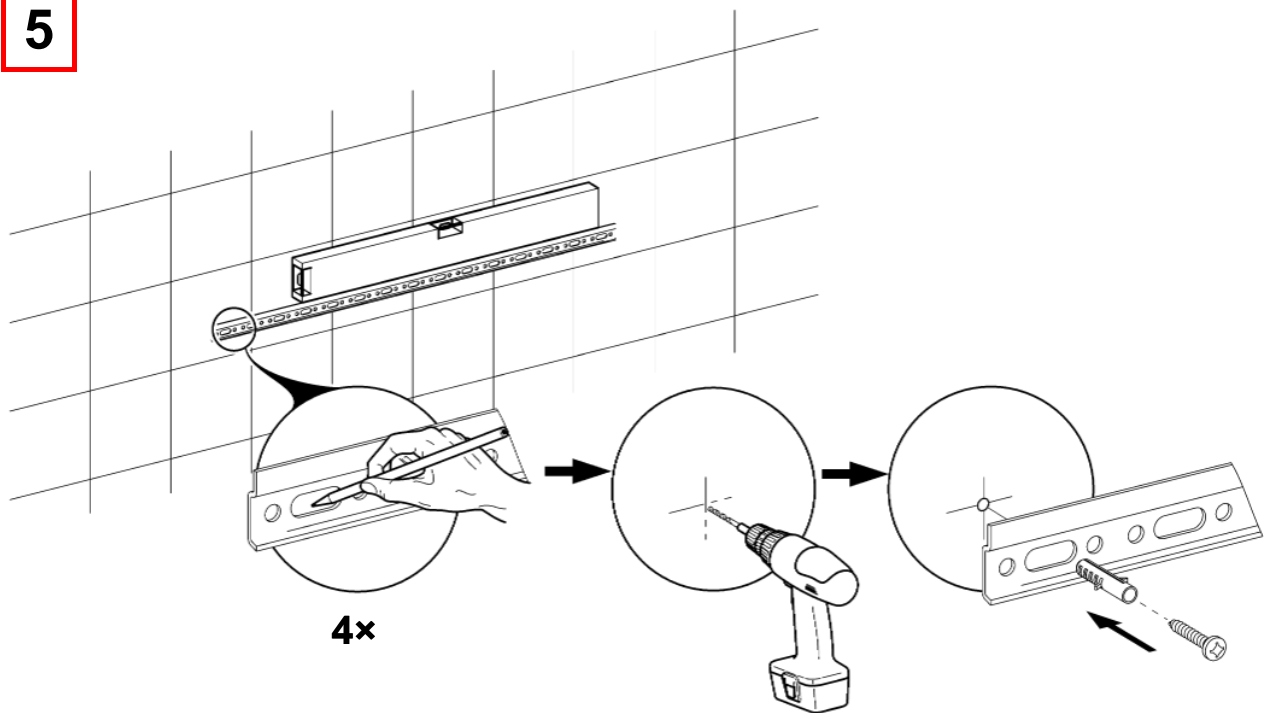

6

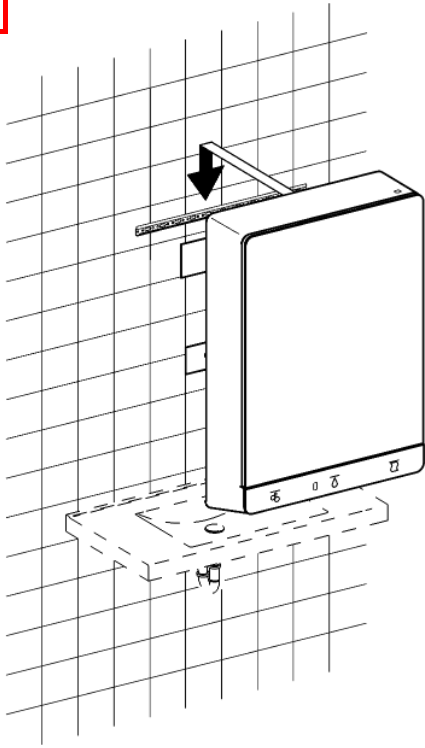

7

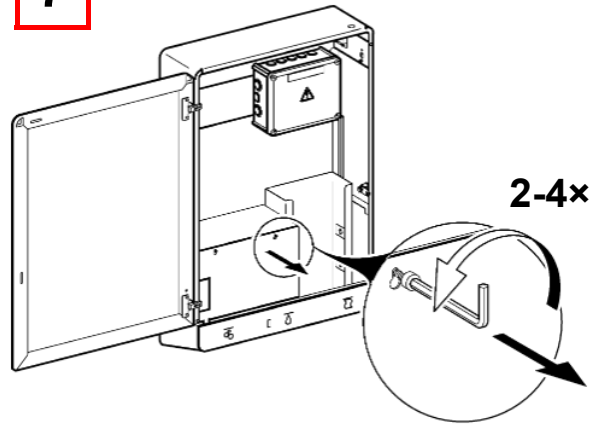

8

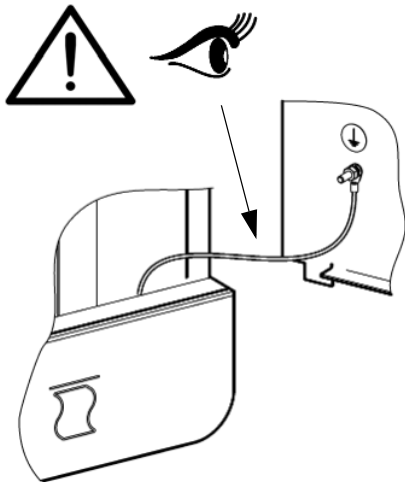
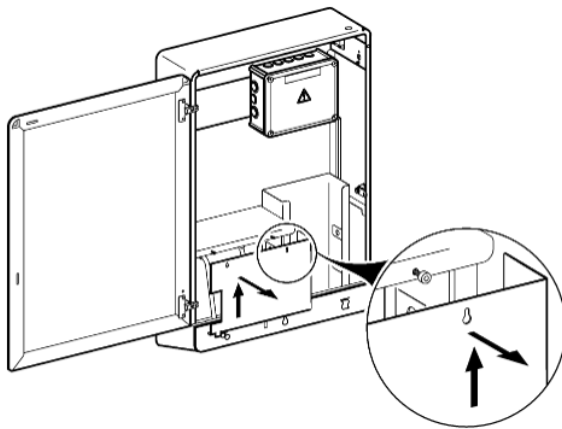

9

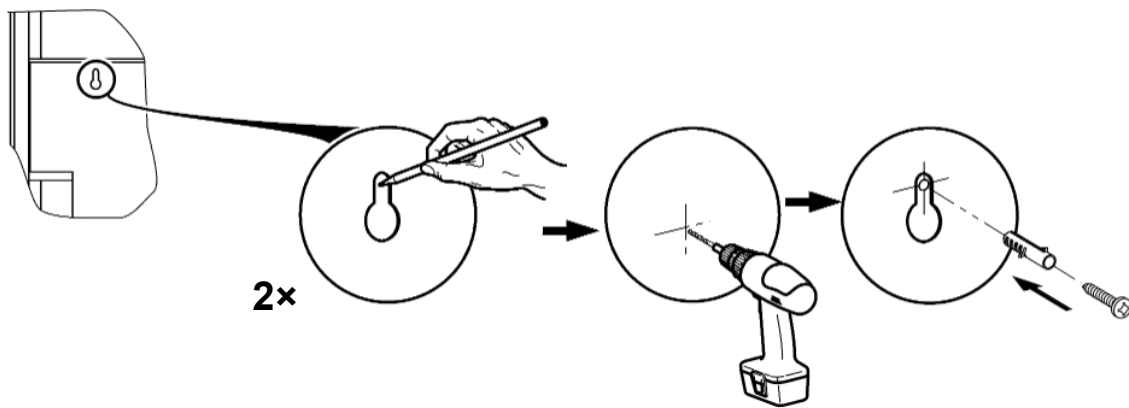

10

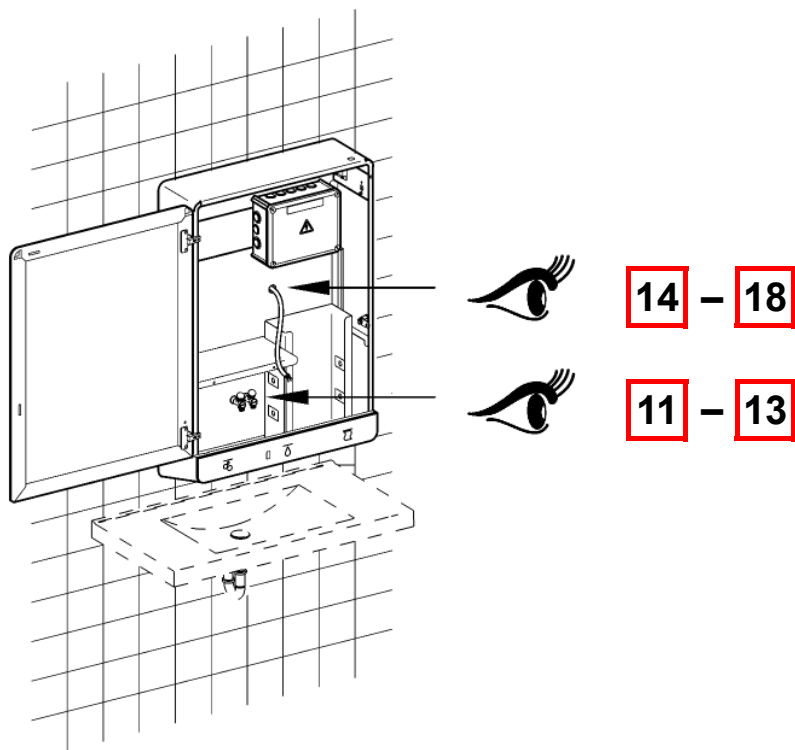

11

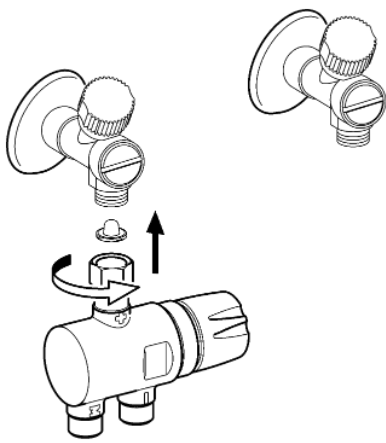

12

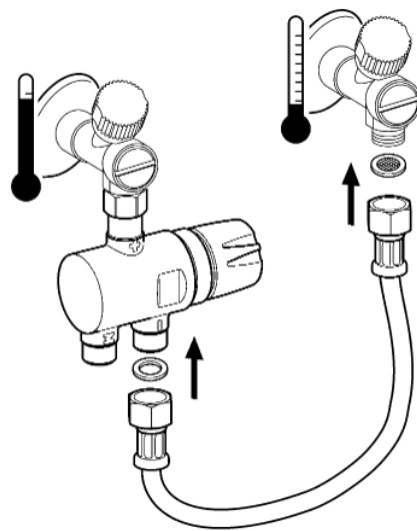

13

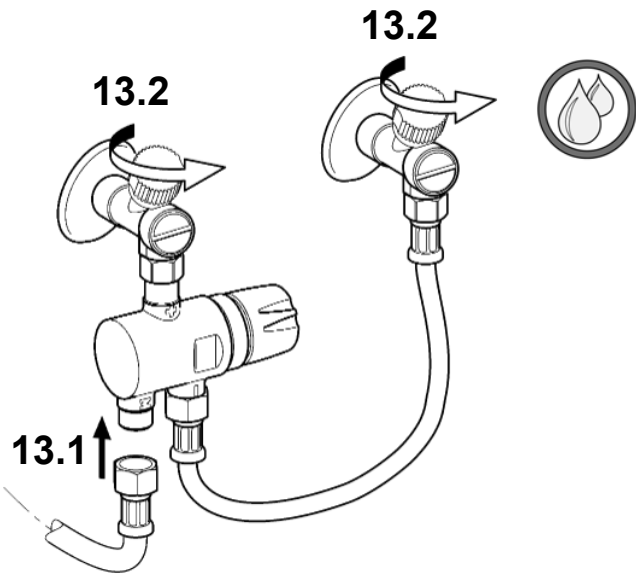
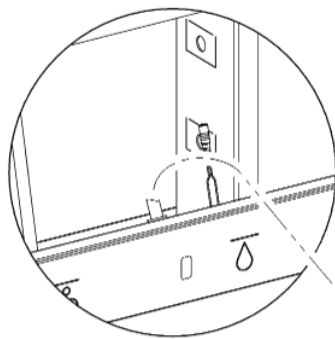

14

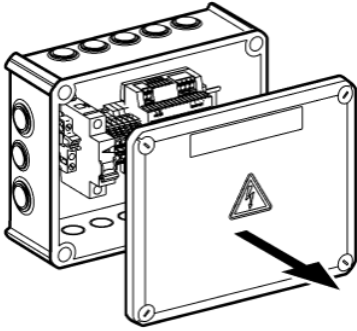

15

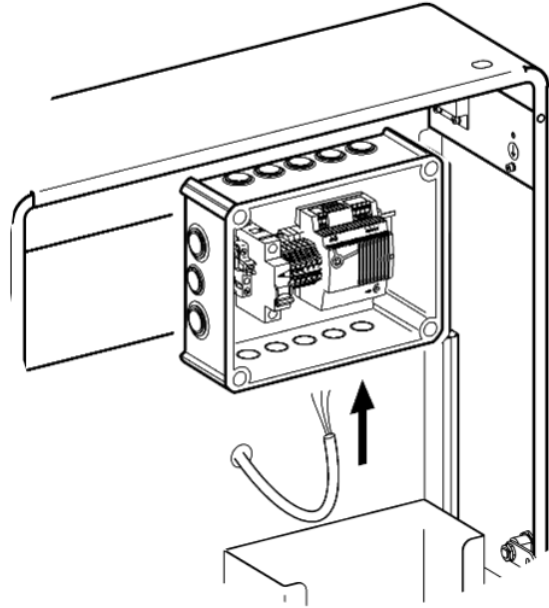

16

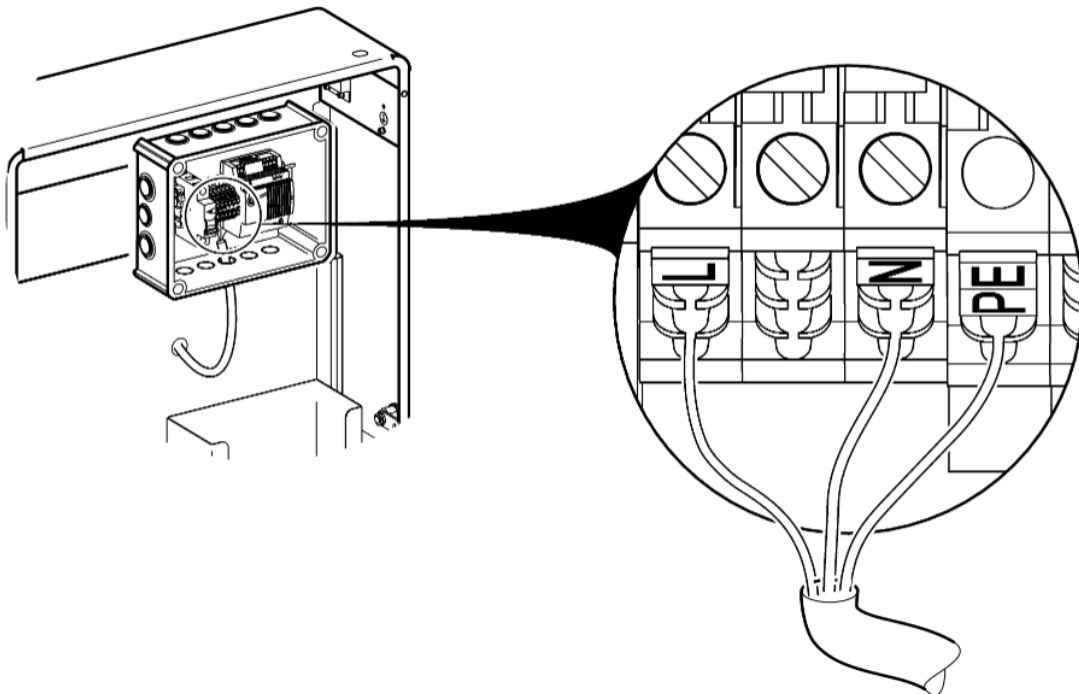

17

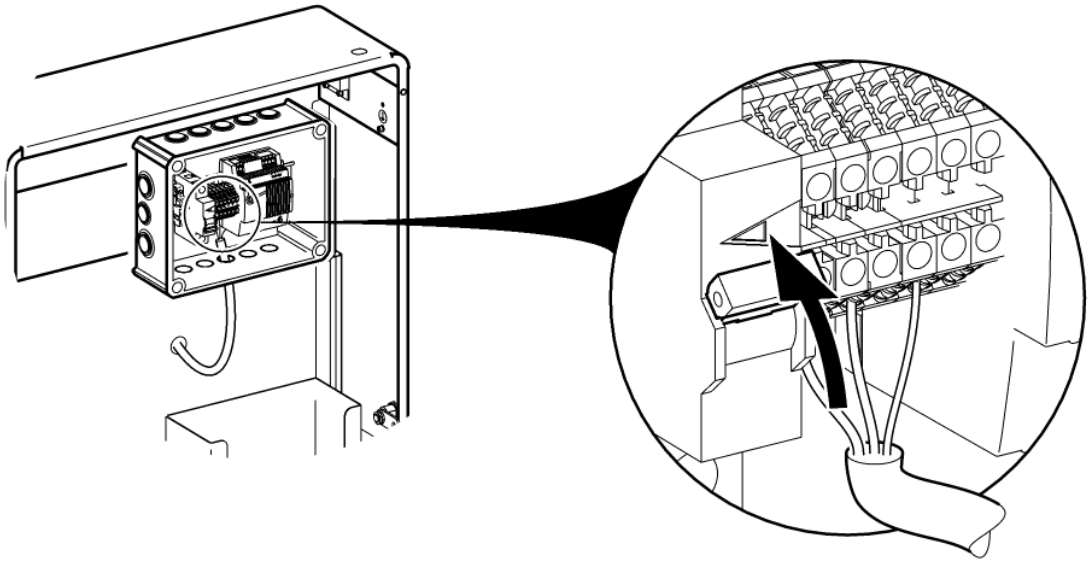
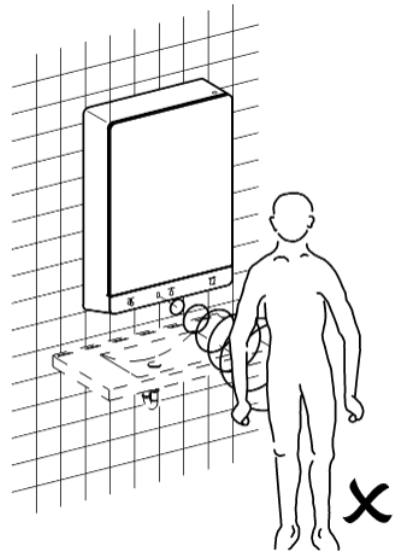
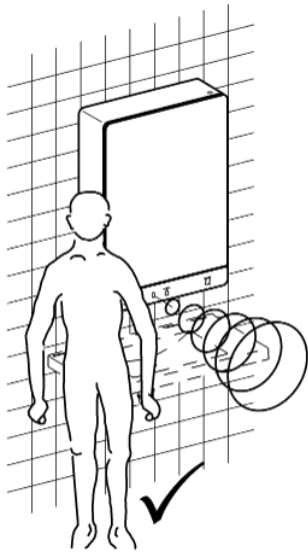

18

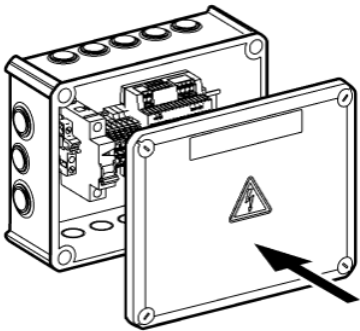

19

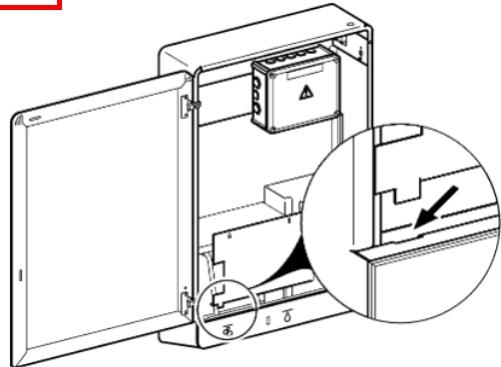

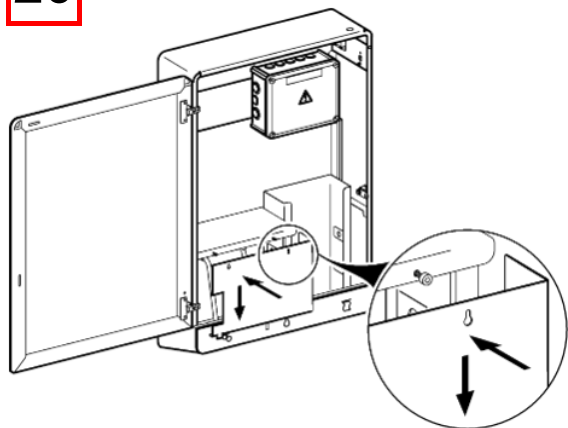
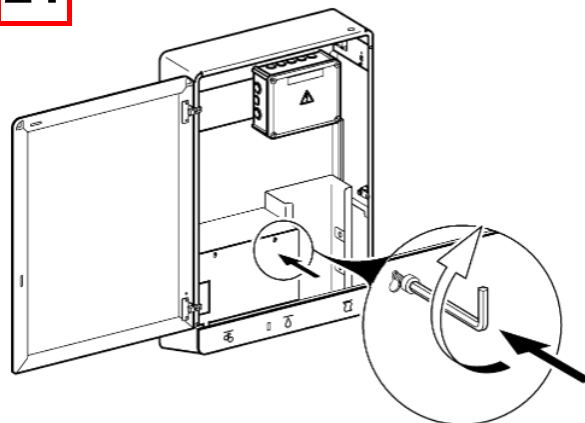
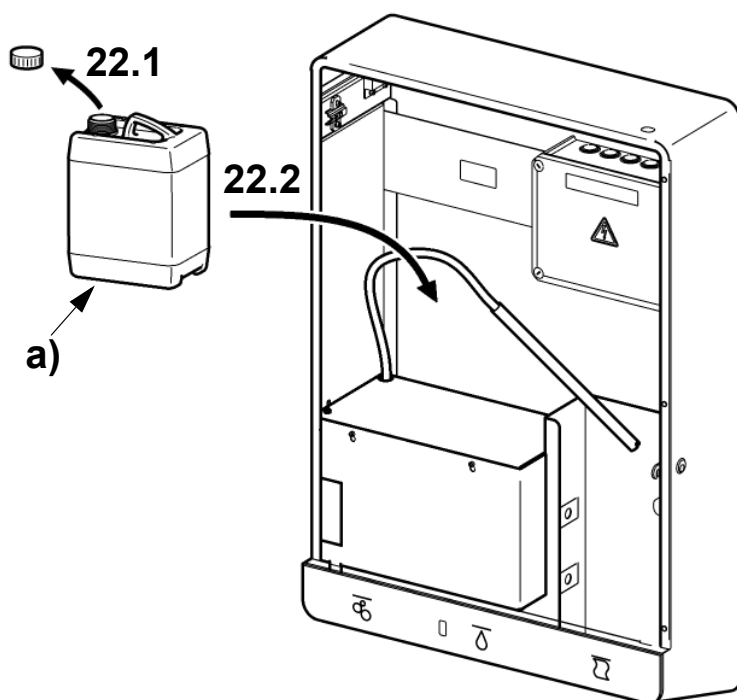
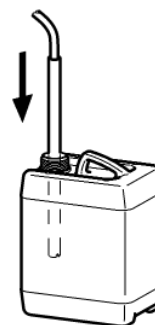
20**21****22****23****EN** a) Not included in scope of delivery**DE** a) nicht Lieferumfang**PL** a) poza zakresem dostawy**SV** a) ngår ej i leveransen**FR** a) non compris dans la livraison**CS** a) Není součástí dodávky**ES** a) no forma parte del volumen de suministro**FI** a) ei kuulu toimitukseen**IT** a) Non compreso nella fornitura**RU** a) Не входит в объём поставки**NL** a) niet bij levering inbegrepen

24

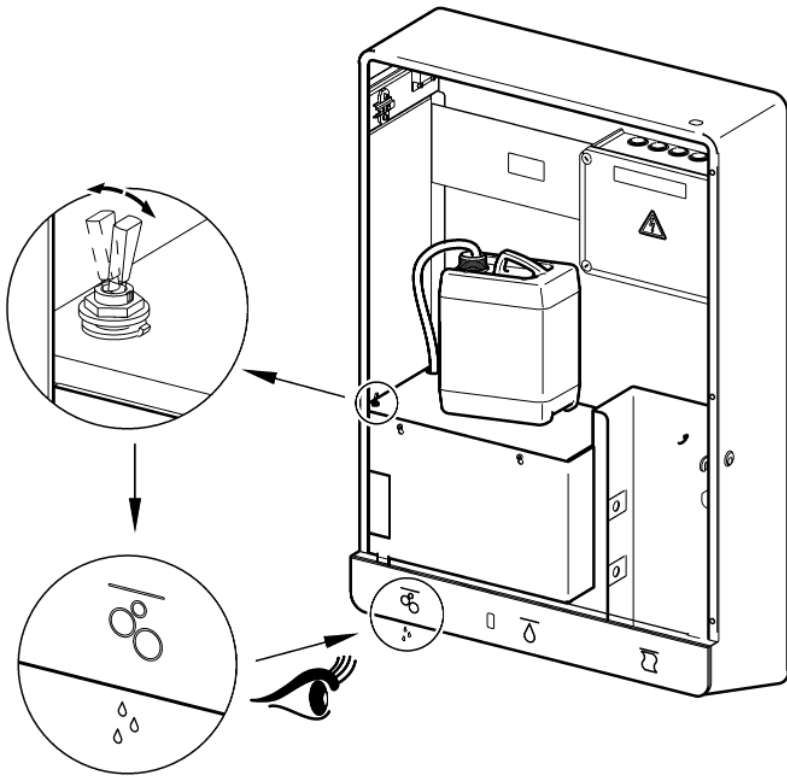

2. Funktion

EN Function
FR Fonctionnement
ES Función
IT Funzionamento

NL Werking
PL Funkcja
SV Funktion

CS Funkce
FI Toiminto
RU Функционирование

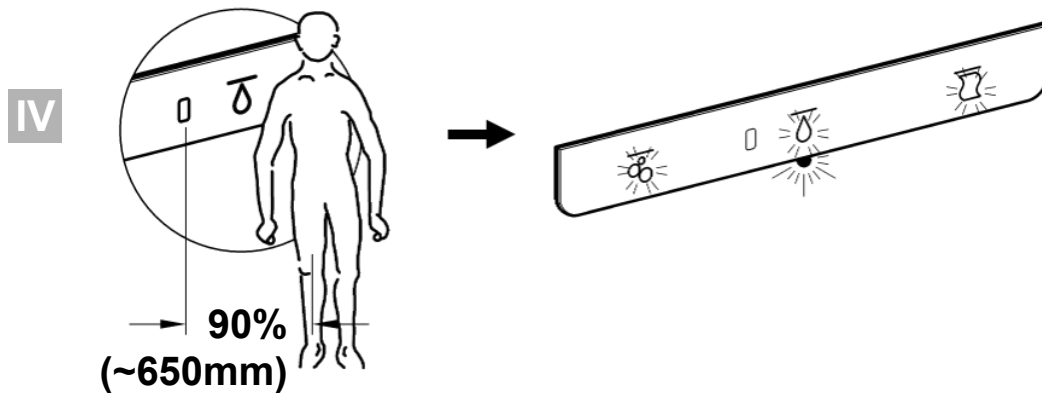
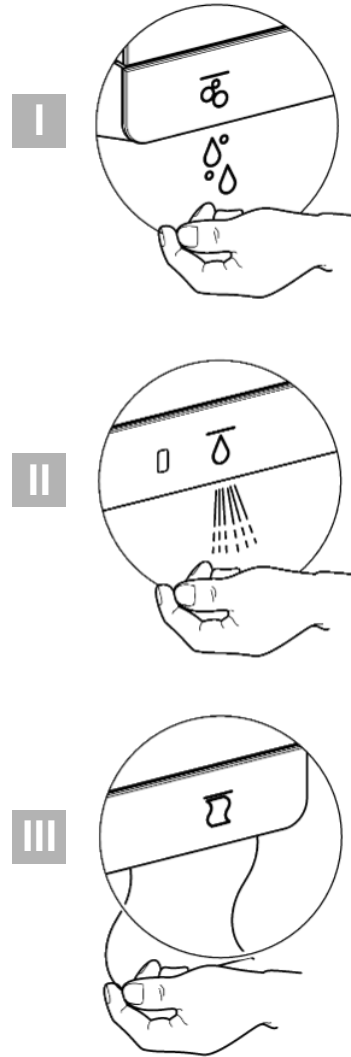
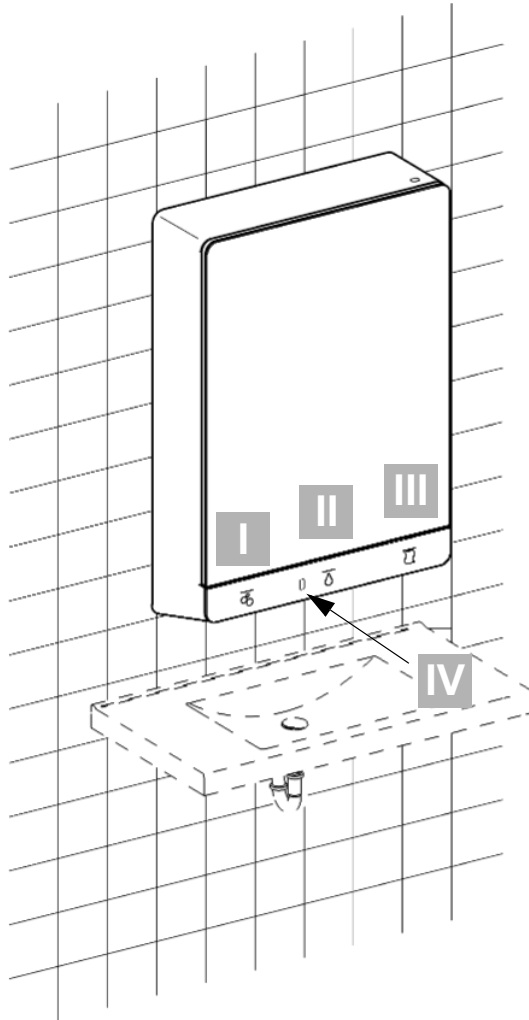

3. Hygienespülung ein-/ausschalten

EN Switching hygiene flushing on/off	NL Hygiënische spoeling in-/uitschakelen	CS Zapněte/vypněte hygienické propláchnutí
FR Activer/désactiver le rinçage hygiénique	PL Włączyć/wyłączyć spłukiwanie higieniczne	FI Hygieniahuhtelun päälle-/ pois päältä kytkeminen
ES Activar/Desactivar el higiene enjuague	SV Koppla hygienspolningen till / från	RU Гигиеническое промывание включить/выключить
IT Attivare/disattivare lo igiene risciacquo		

EN

- Ensure open outlet.
- After 24h of non-use, water flows 30 sec.

DE

- Freien Auslauf gewährleisten.
- Nach 24h Nichtbenutzung fließt 30 sec Wasser.

FR

- Garantir un écoulement libre.
- L'eau s'écoule pendant 30 sec. après 24h de non utilisation.

ES

- Garantizar una salida libre.
- Si no se realiza ningún uso durante 24 horas, fluye agua durante 30 segundos.

IT

- Garantire l'erogazione libera.
- Dopo 24h di inutilizzo scorre acqua per 30 sec.

NL

- Vrije uitloop garanderen.
- Na 24 uur niet te zijn gebruikt stroomt er gedurende 30 sec. water.

PL

- Zapewnić swobodny wylot.
- Po 24 godz. niekorzystania przez 30 s. wypływa woda.

SV

- Garantera fritt avlopp.
- Vatten flyter 30 sek efter 24 timmars användningspaus.

CS

- Zajistěte volný odtok.
- Při nepoužívání 24 h nechte 30 s téct vodu.

FI

- Vapaan virtauksen takaaminen.
- Käyttämättömänä 24 h jälkeen virtaa vettä 30 s.

RU

- Обеспечить беспрепятственный слив
- После того, как устройство не используется в течение 24 ч, в течение 30 сек течёт вода.

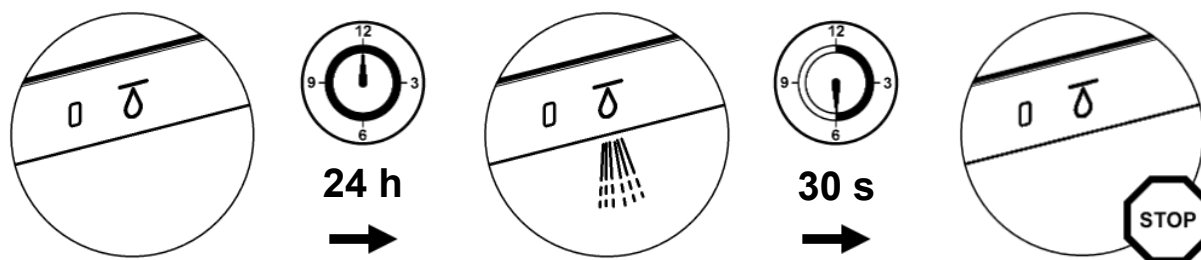



4. Armatur ausschalten

EN Switch off the valve

FR Désactiver la robinetterie de

ES Desconectar la grifería

IT Disattivazione della rubinetteria

NL Armatuur uitschakelen

PL Wyłączenie baterii

SV Avstängning av armatur

CS Vypnout armaturu

FI Hanan kytkeminen pois päältä

RU Выключение смесителя



5. Reinigungsabschaltung einschalten

EN Switch on cleaning switch-off	NL Inschakelen van de reiniging shutdown	CS Vypínač pro čištění
FR Activer l'arrêt de nettoyage	PL Włączanie wyłączenia na czas czyszczenia	FI Aktivoida pesuseisokkien
ES Activar el apagado de limpieza	SV Aktivera rengörings avstängning	RU активировать чистка завершение работы
IT Attivare dello spegnimento per pulizia		

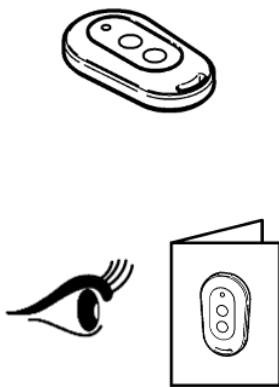
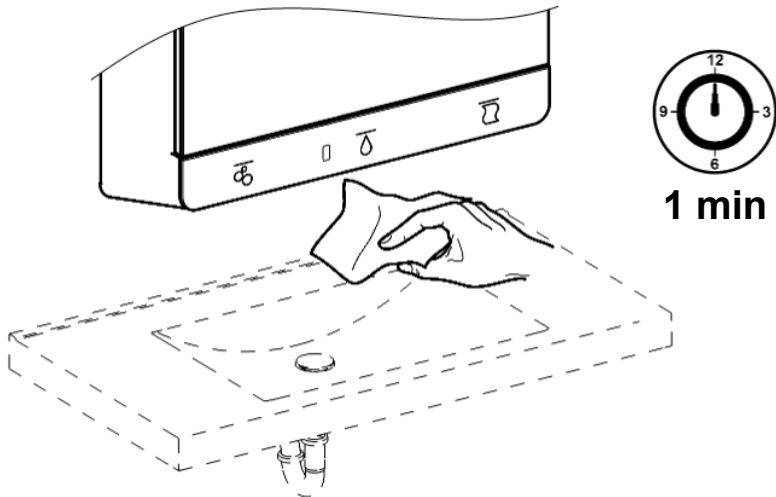

6. Reichweite einstellen

EN Adjusting the range
FR Réglage de la portée
ES Ajuste del alcance
IT Impostazione della portata

NL Actieradius instellen
PL Ustawienie zasięgu
SV Ställa in räckvidden

CS Nastavení dosahu
FI Tunnistusetäisyyden säätäminen
RU Настройка дальности действия

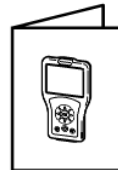
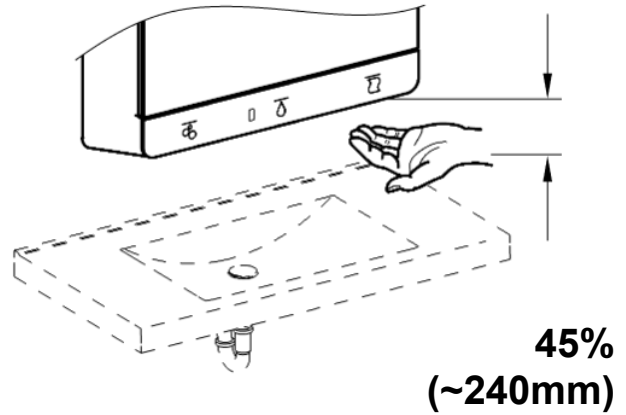
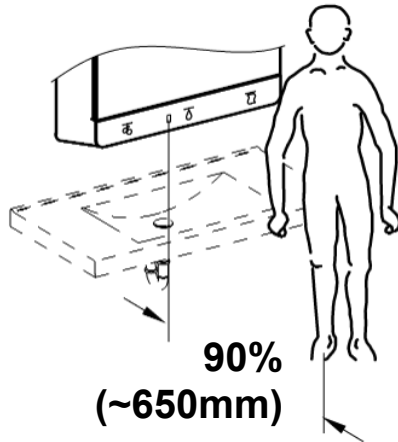

1 – 100%
(1 – 700mm)

7. Hygienespülung einstellen

EN Setting the hygiene flush	NL Instellen van de hygiënespoeling	CS Nastavení hygienického proplachování
FR Réglage de la rinçage d'hygiène	PL Ustawianie spłukiwania higienicznego	FI Hygieniahuuhtelun säätäminen
ES Ajuste del higiene enjuague	SV Ställa in hygienspolning	RU установив гигиена смыва
IT Impostare lo igiene risciacquo		

EN

- ▶ C: Interval adjustable in h
- ▶ D: Flow duration adjustable in s

DE

- ▶ C: Intervall einstellbar in h
- ▶ D: Fließzeit einstellbar in s

FR

- ▶ C: intervalle réglable en h
- ▶ D: durée d'écoulement réglable en s

ES

- ▶ C: Intervalo ajustable en horas
- ▶ D: Tiempo de flujo activable en seg

IT

- ▶ C: intervallo impostabile in h
- ▶ D: durata di flusso impostabile in s

NL

- ▶ C: Interval instelbaar in u
- ▶ D: Stromingstijd instelbaar in s

PL

- ▶ C: odstęp czasu regulowany w godzinach
- ▶ D: czas przepływu regulowany w sekundach

SV

- ▶ C: Intervall kan ställas in i timmar
- ▶ D: Flödestid kan ställas in i sekunder

CS

- ▶ C: Interval s nastavením v h
- ▶ D: Doba průtoku s nastavením v s

FI

- ▶ C: Aikaväli, asetettavissa h
- ▶ D: Virtausaika, asetettavissa s

RU

- ▶ C: интервал задается в ч
- ▶ D: время течения задается в сек.

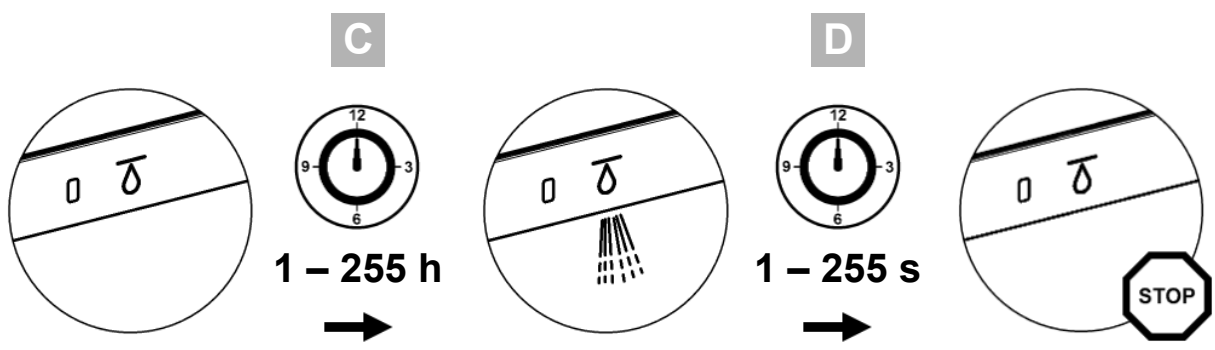
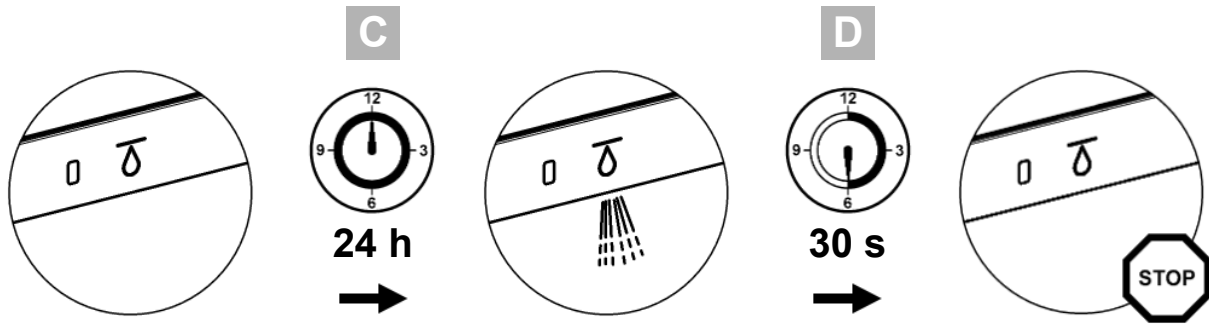

8. Reinigungsabschaltung einstellen

EN Adjusting the cleaning switch-off	NL Reinigingsuitschakeling instellen	CS Nastavení vypnutí za účelem čištění
FR Régler l'arrêt du nettoyage	PL Ustawianie funkcji wyłączenia na czas czyszczenia	FI Puhdistuskatkaisun säätäminen
ES Ajuste de la desconexión de limpieza	SV Ställa in rengörings avstängning	RU Настройка отключения для очистки
IT Impostazione dello spegnimento per pulizia		

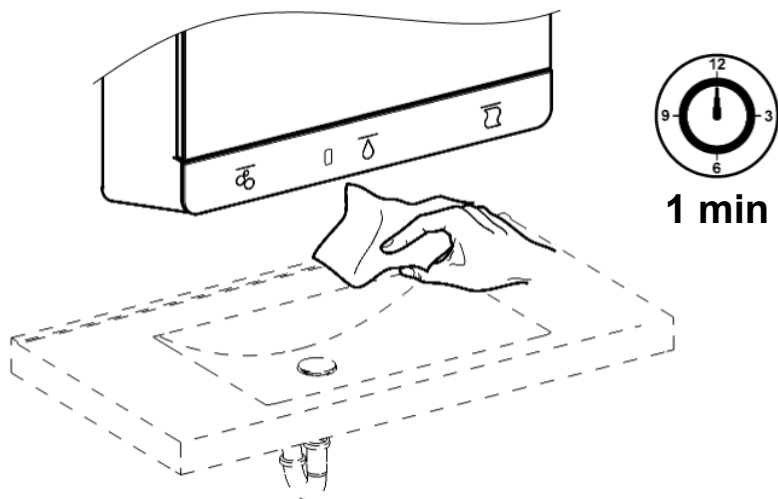

1 – 255 min

9. Wartung

EN Maintenance
FR Maintenance
ES Mantenimiento
IT Manutenzione

NL Onderhoud
PL Konserwacja
SV Underhåll

CS Varování
FI Huolto
RU Техническое обслуживание



10.

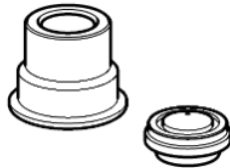

11.

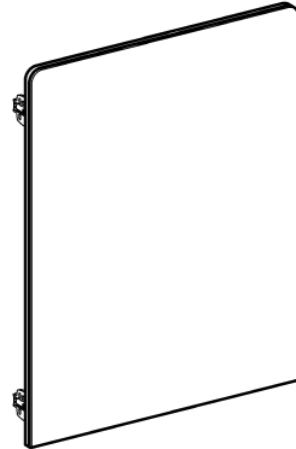

12.

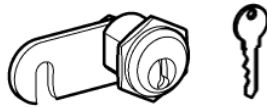

13.

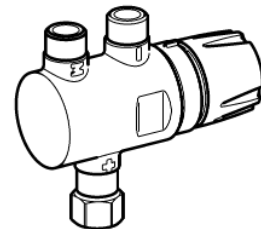

14.

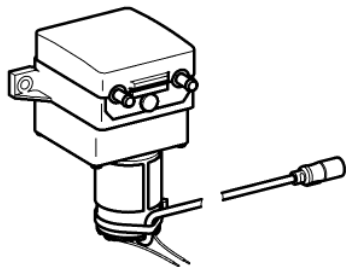

15.

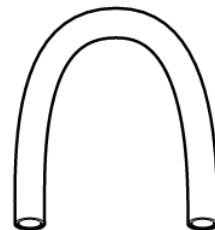



16.

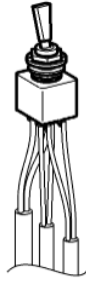

17.

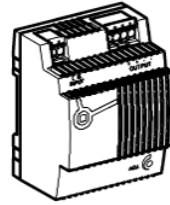

18.

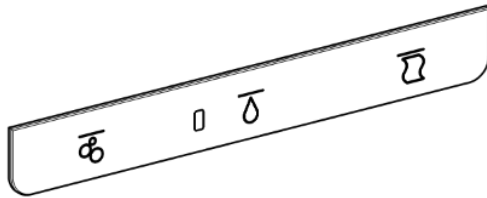

19.

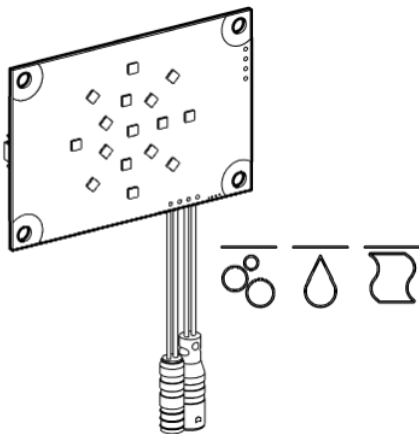



20.

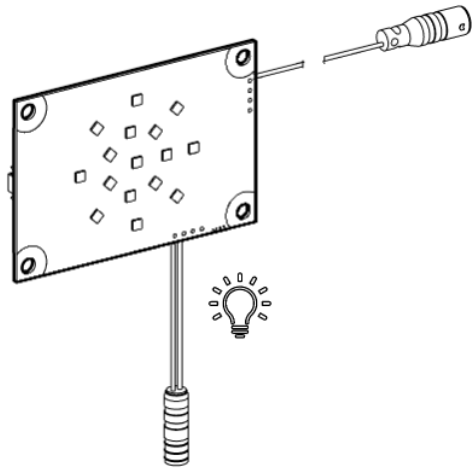

21.

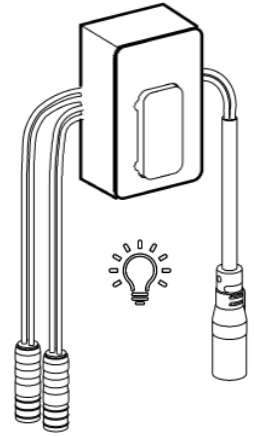

22.

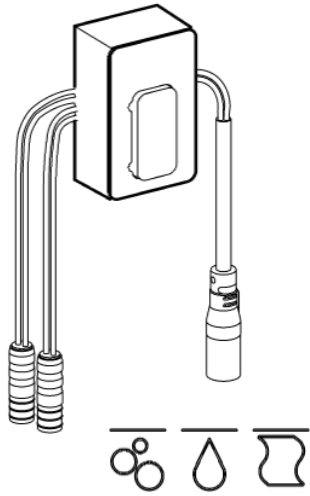

23.

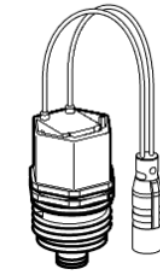

10. Perlator und Aufnahme wechseln

EN Replace the aerator and holder	NL Perlator en houder vervangen	CS Výměna perlátoru a úchytu
FR Remplacement du perlator et du logement	PL Wymiana perlatora i mocowania	FI Vaihda ilmastin ja ilmanoton vaihto
ES Cambio del difusor y el alojamiento	SV Byta spolreglage och fäste	RU Замена перлатора и фиксатора
IT Sostituzione di Perlator e sede		

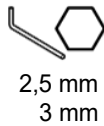

1

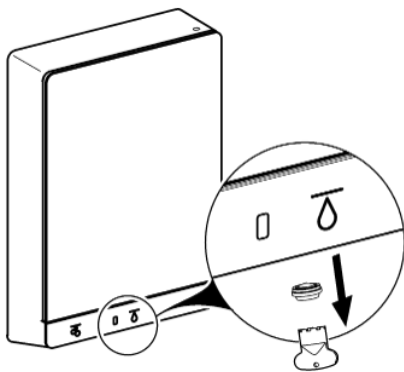

2

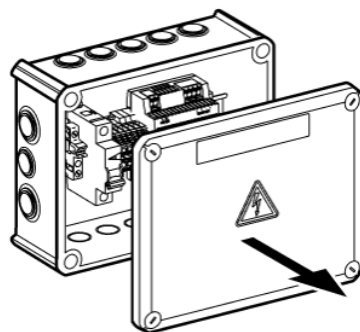

3

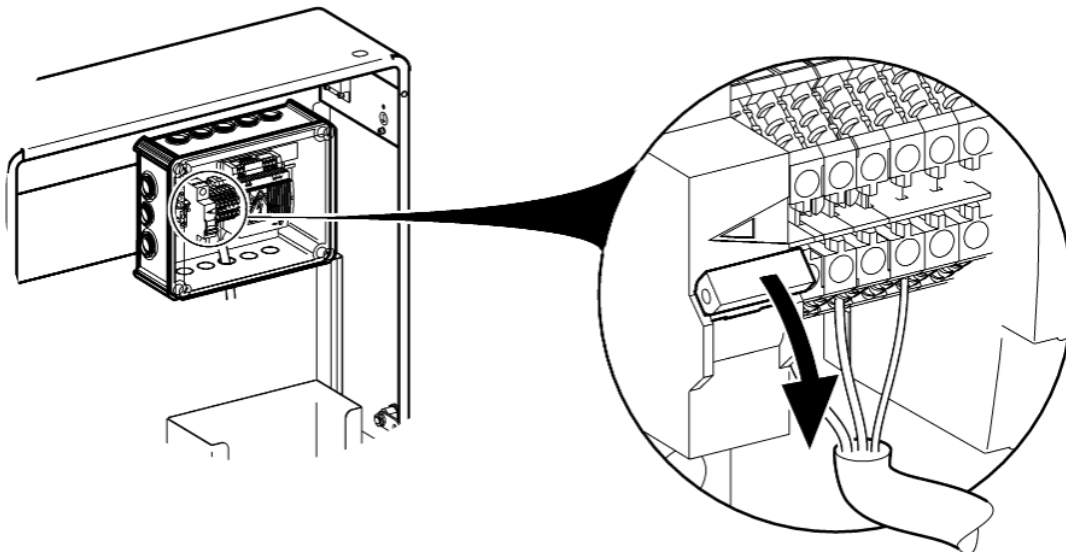

4

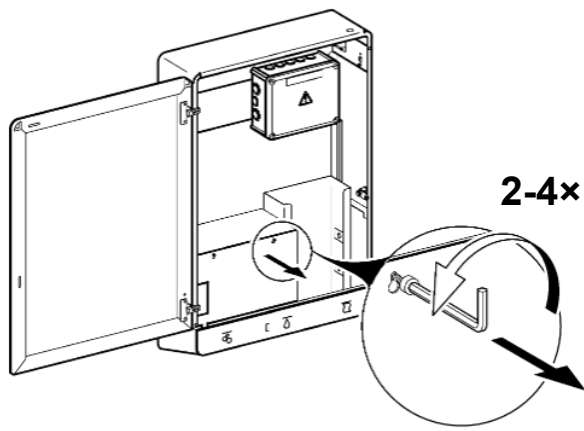

5

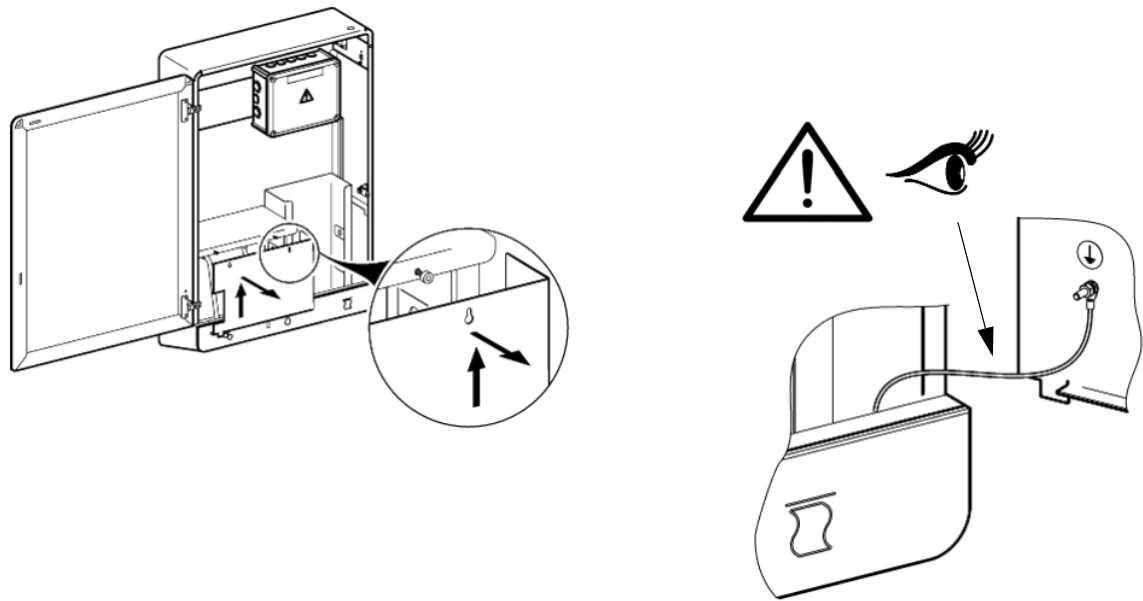

6

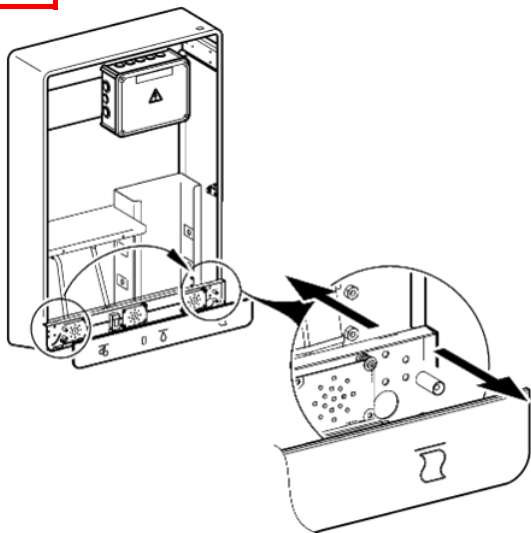

7

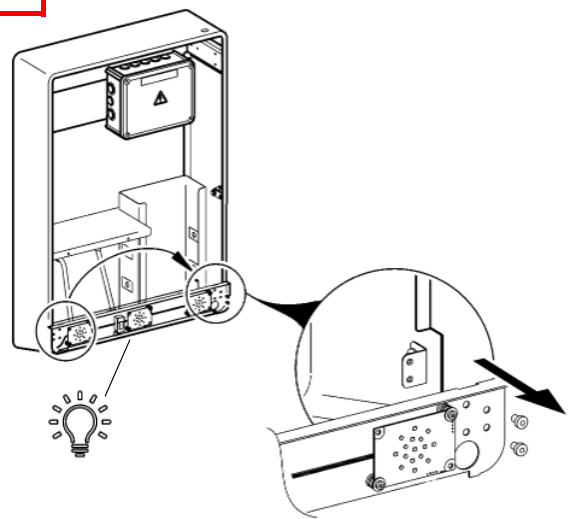

8

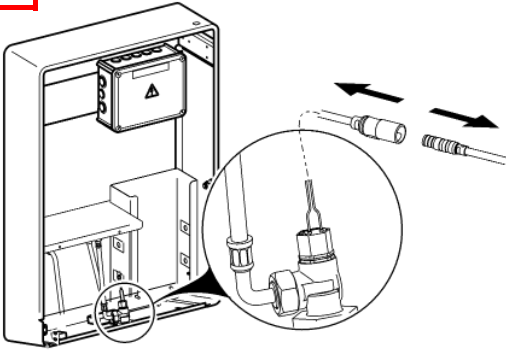

9

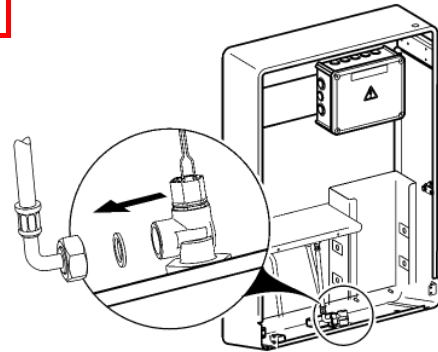

10

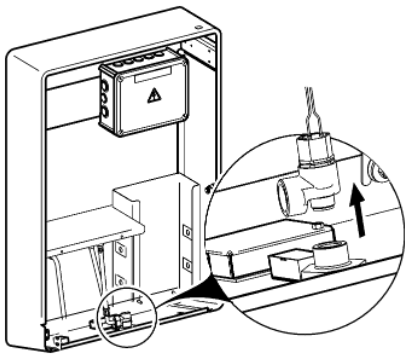

11

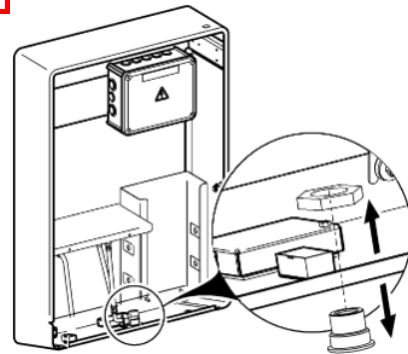

12

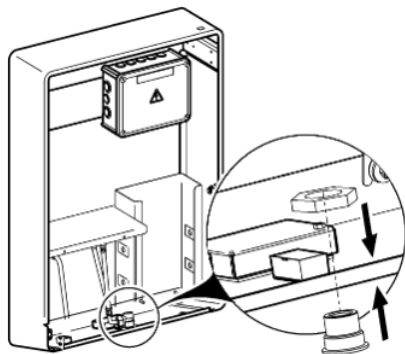

13

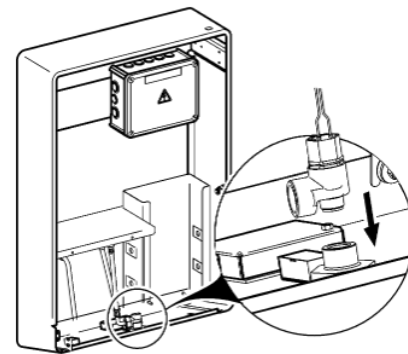

14

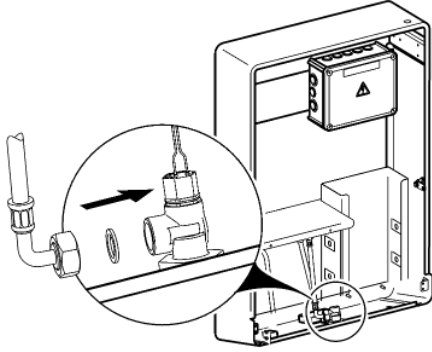

15

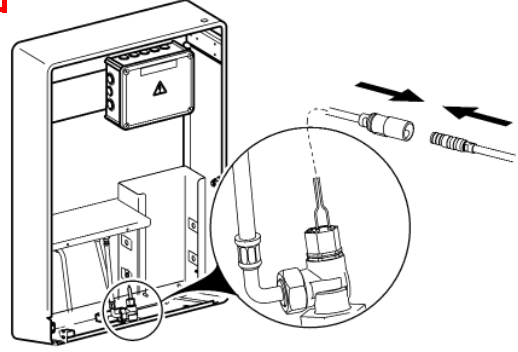

16

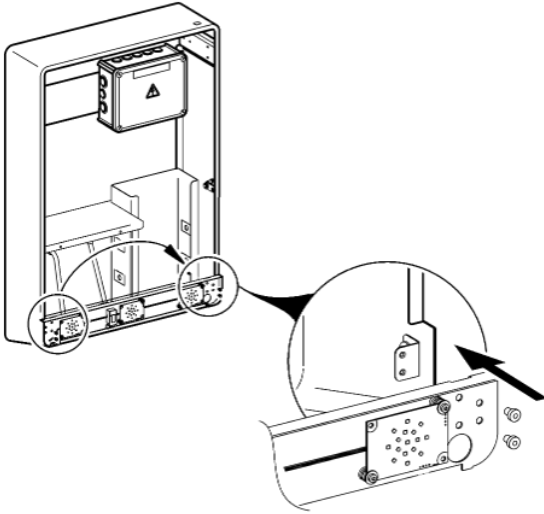

17

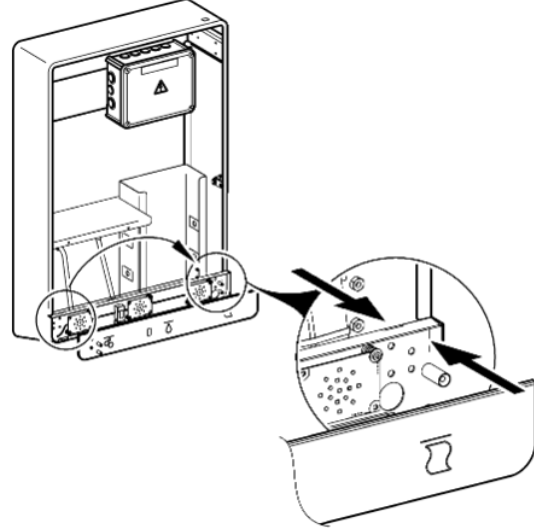

18

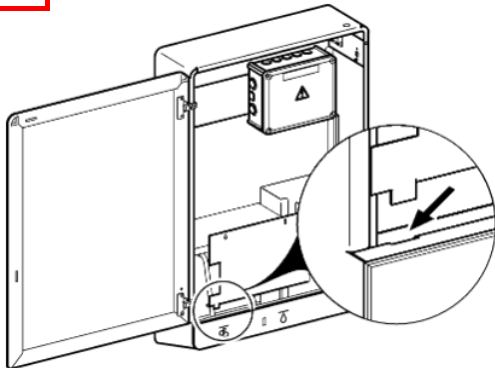

19

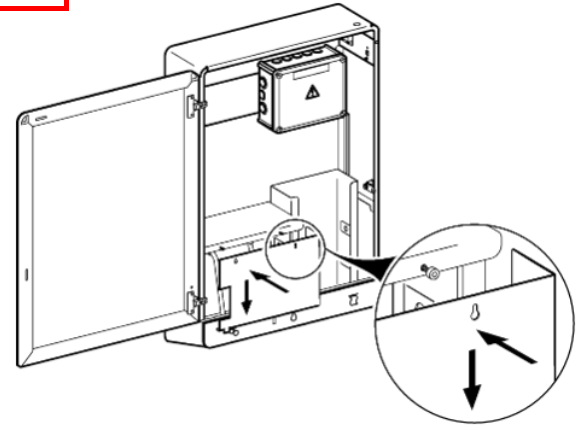

20

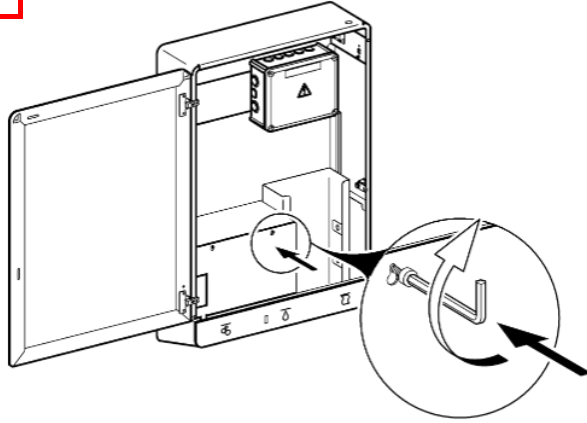

21

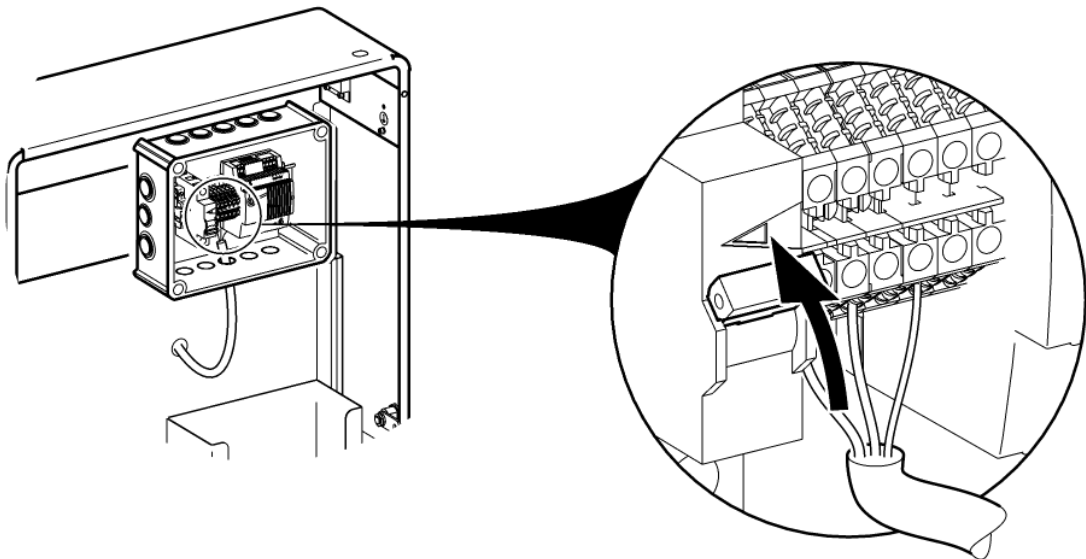
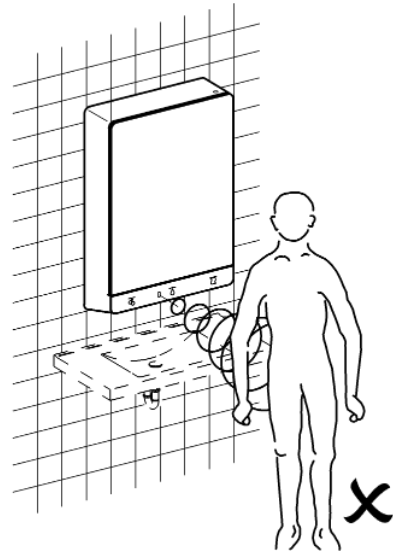
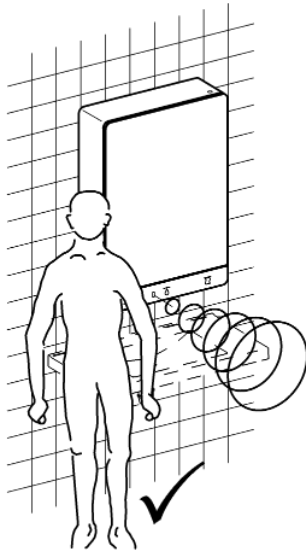

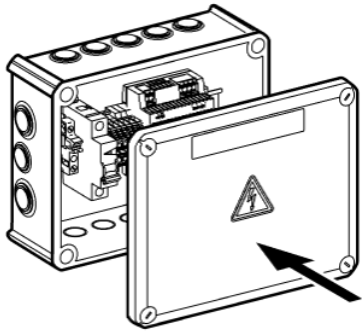
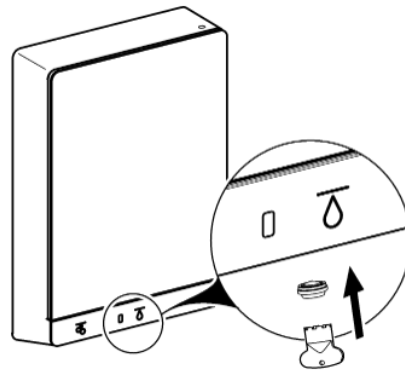
22**23**

11. Tür wechseln

EN Replace the door

FR Remplacement de la porte

ES Cambio de la puerta

IT Sostituzione dello sportello

NL Deur vervangen

PL Wymiana drzwi

SV Byta dörr

CS Výměna dveří

FI Oven vaihto

RU Замена двери

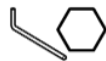

3 mm

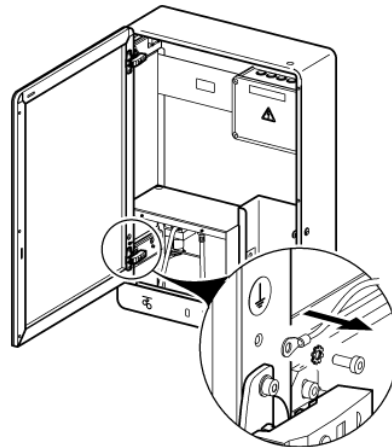
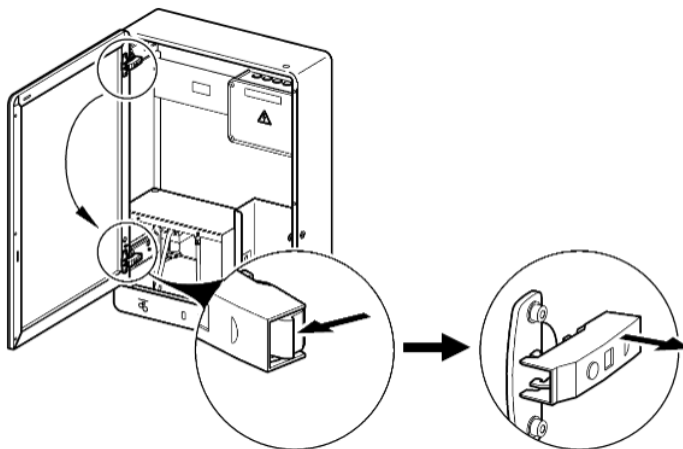
**1****10.****4 - 5****2****3**

4

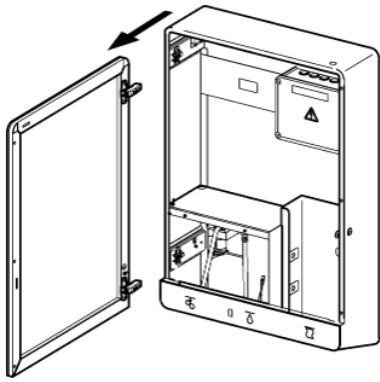

5

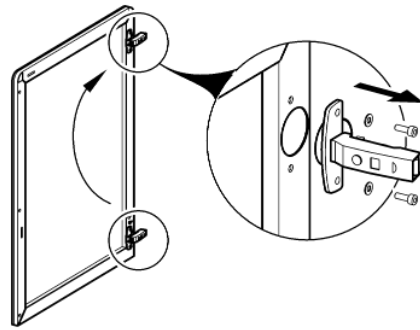

6

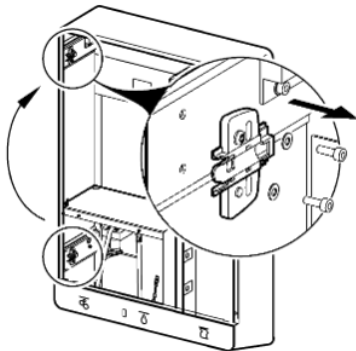

7

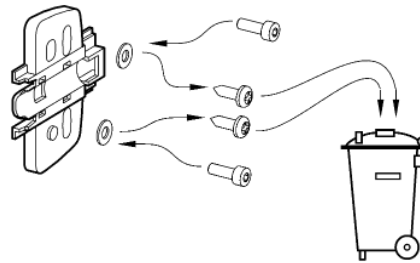

8

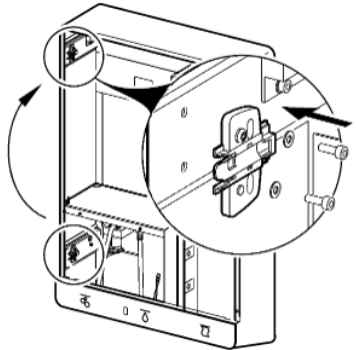

9

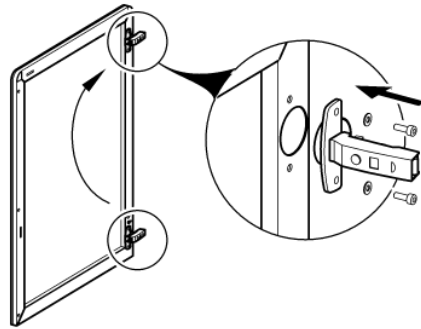

10

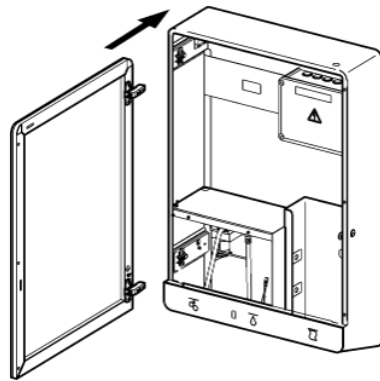

11

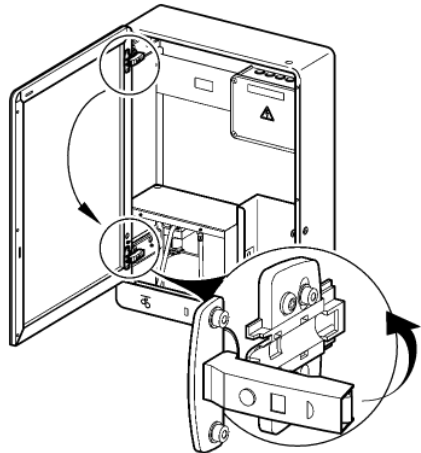

12

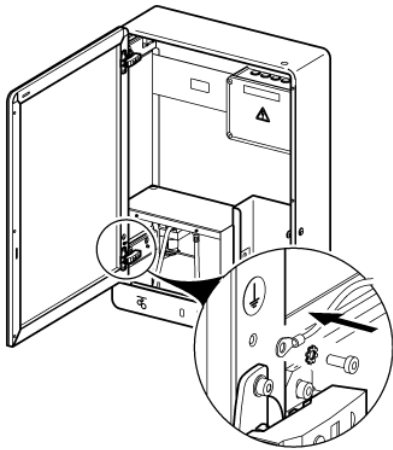

13



10.

18 - 20

14

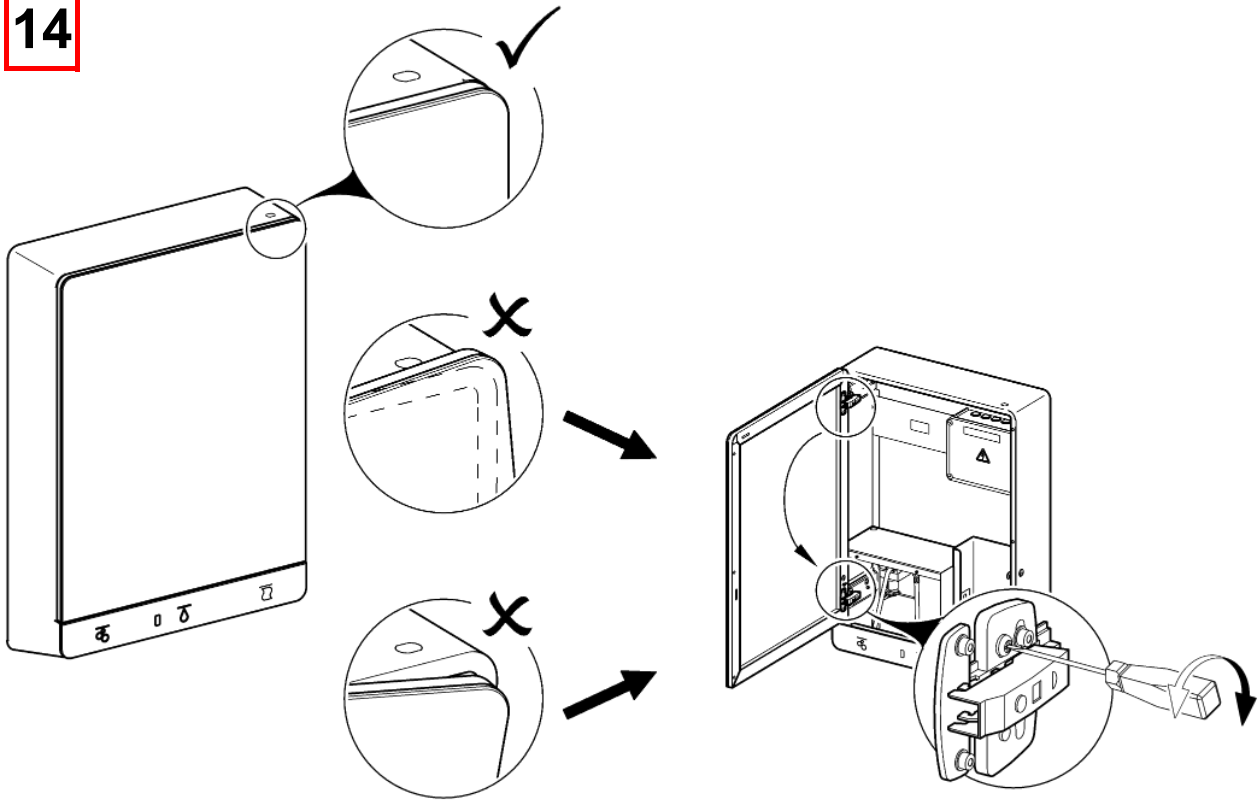

12. Schloss wechseln

EN Replace the lock

FR Remplacement de la serrure

ES Cambio de la cerradura

IT Sostituzione della serratura

NL Slot vervangen

PL Wymiana zamka

SV Byta lås

CS Výměna zámku

FI Lukon vaihto

RU Замена замка



15 mm



24 mm

1

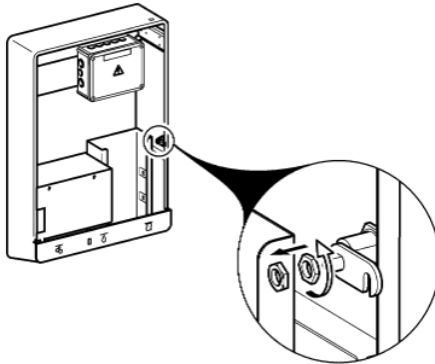

2

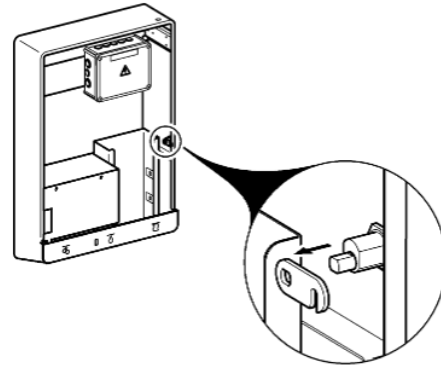

3

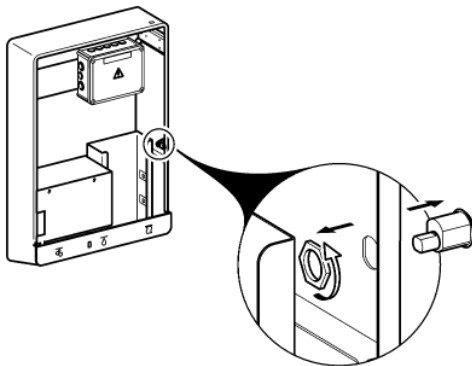

4

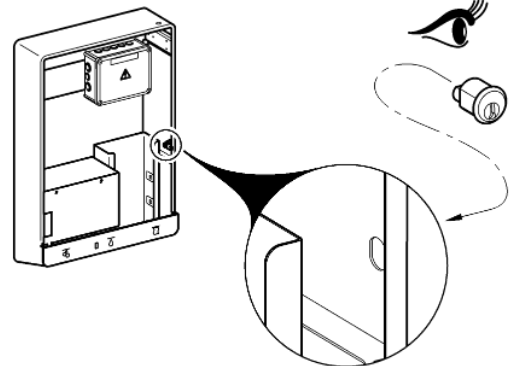

5

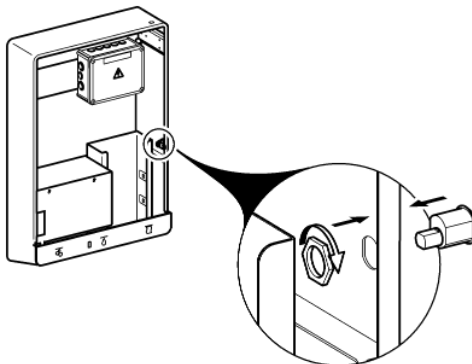

6

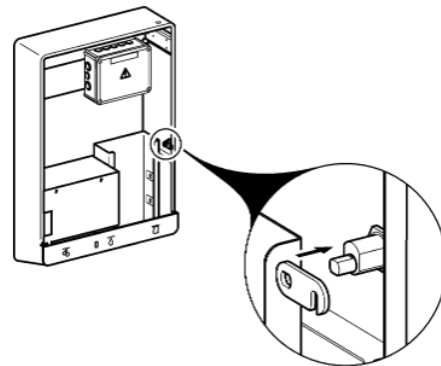

7

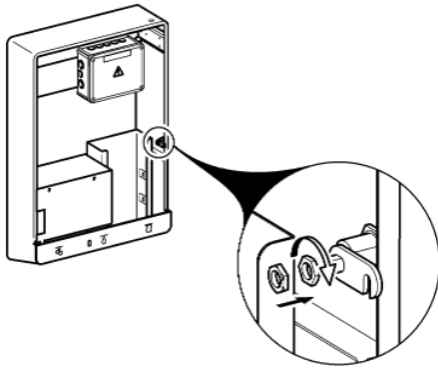

13. Thermostat wechseln

EN Replace the thermostat
 FR Remplacement du thermostat
 ES Cambio del termostato
 IT Sostituzione del termostato

NL Thermostaat vervangen
 PL Wymiana termostatu
 SV Byta termostat

CS Výměna termostatu
 FI Termostaatin vaihto
 RU Замена термостата

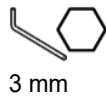

1

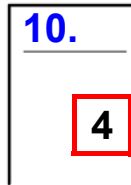

2

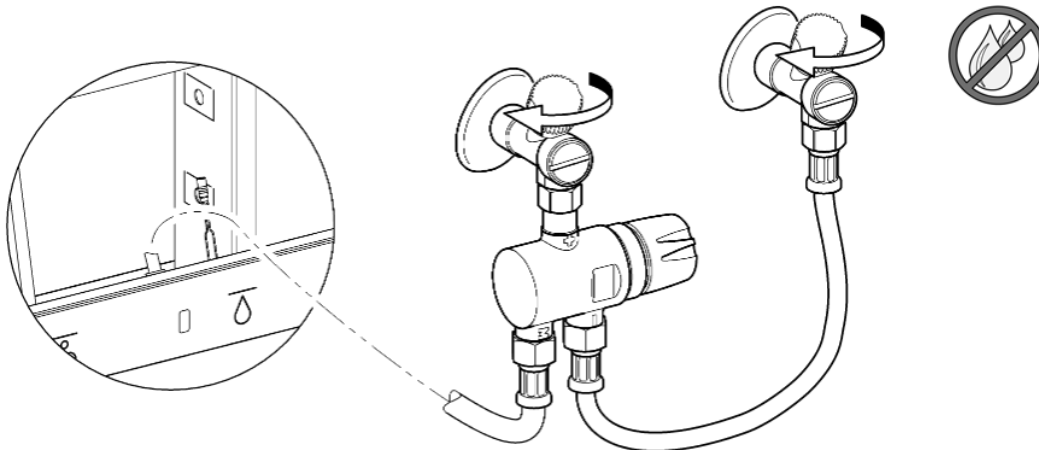

3

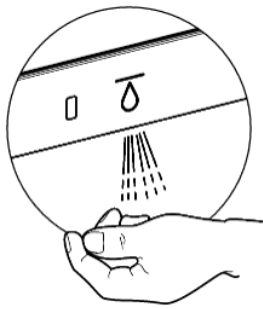

4

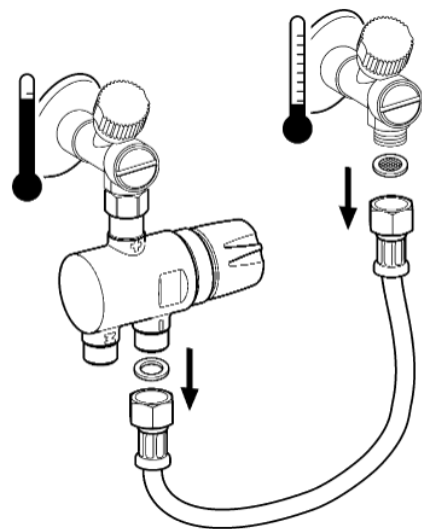

5

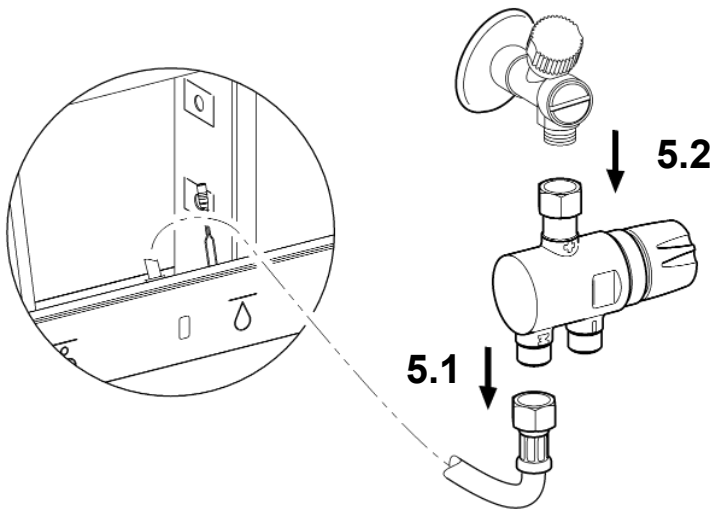

6

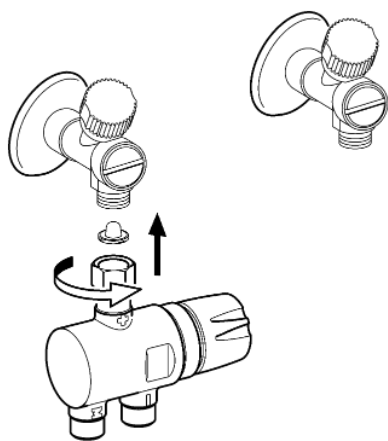

7

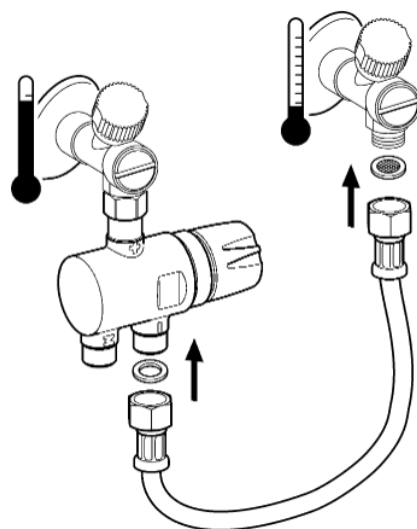

8

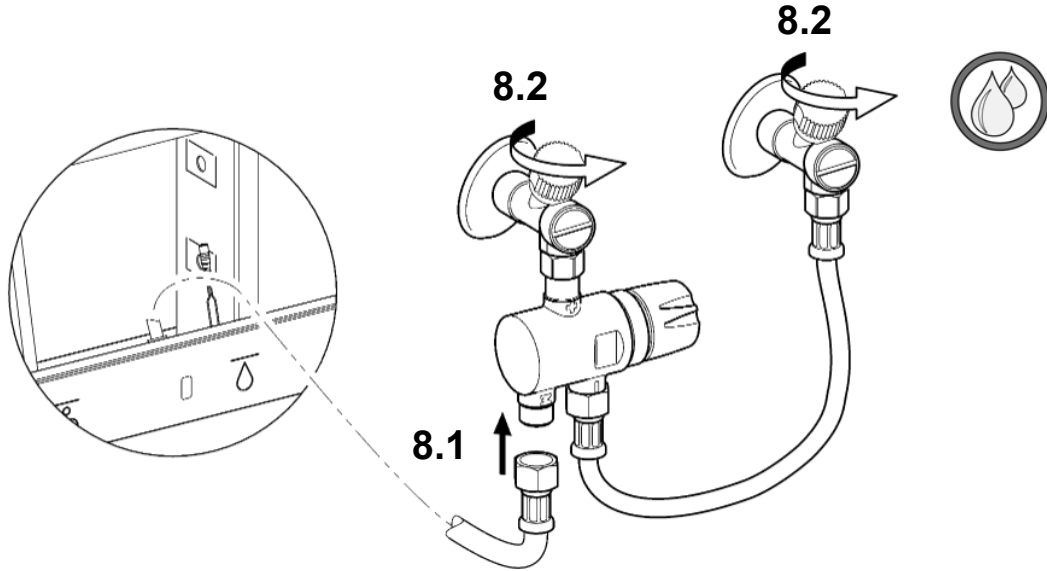

9



10.

18 - 20

14. Dosierpumpe wechseln

EN Replace the dosing pump

NL Doseerpomp vervangen

CS Výměna dávkovací pumpy

FR Remplacement de la pompe de dosage

PL Wymiana pompy dozującej

FI Annostelupumpun vaihto

ES Cambio de la bomba dosificadora

SV Byta doseringspump

RU Замена дозирующего насоса

IT Sostituzione della pompa dosatrice



1



10.

2 - **5**

2

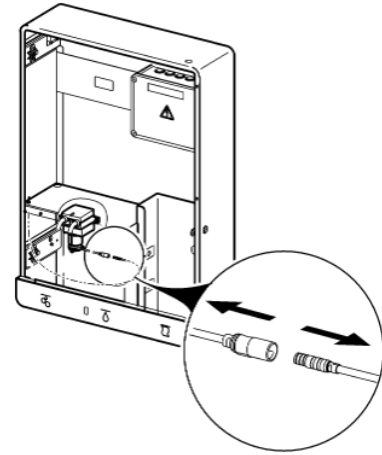

3

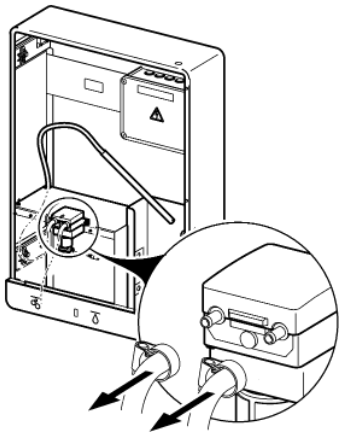

4

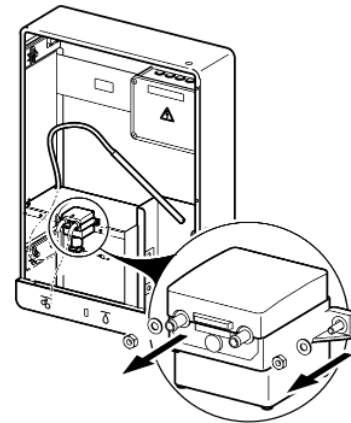

5

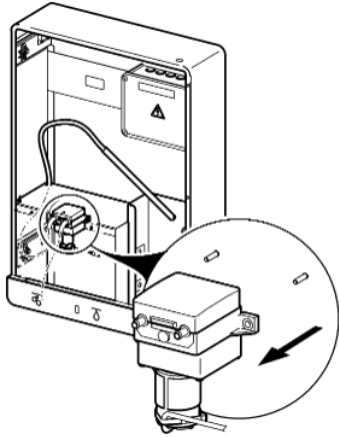

6

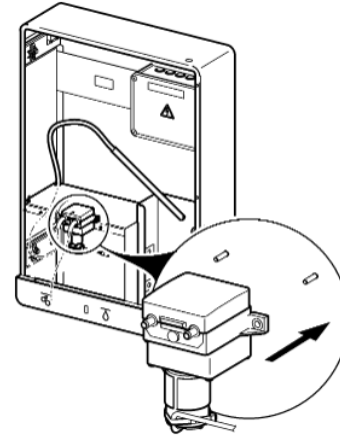

7

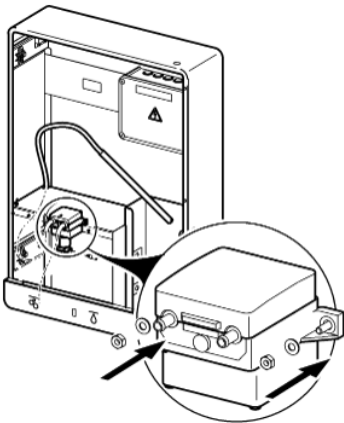

8

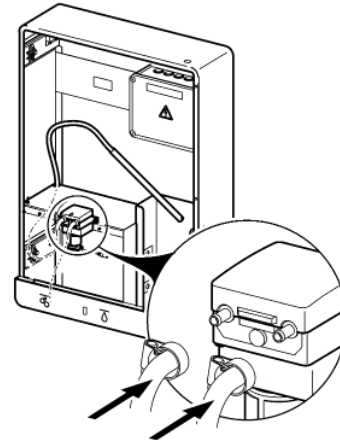

9

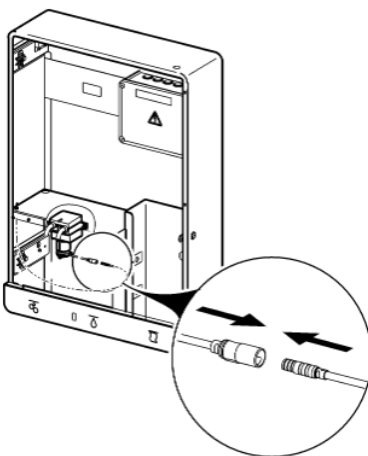

10



10.

18 - 22

15. Schlauch wechseln

EN Replace the hose

FR Remplacement du flexible

ES Cambio del tubo

IT Sostituzione del flessibile

NL Slang vervangen

PL Wymiana węża

SV Byta slang

CS Výměna hadice

FI Letkun vaihto

RU Замена шланга



1



14.

1 - **5**

2

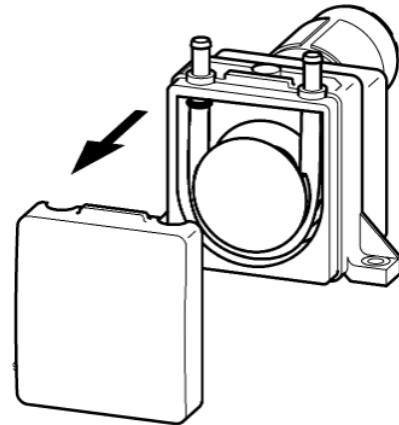

3

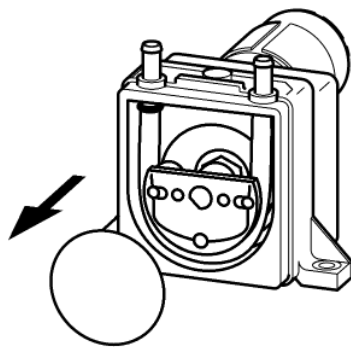

4

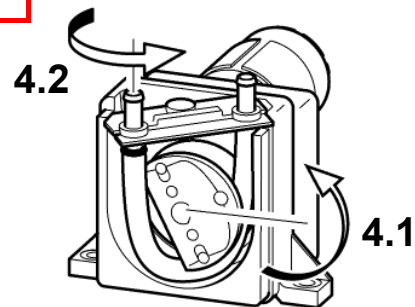

5

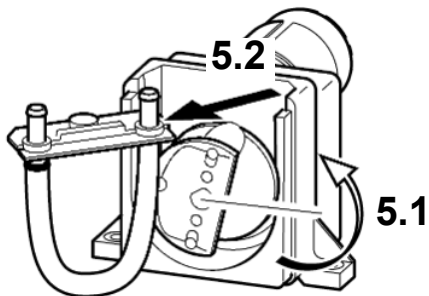

6

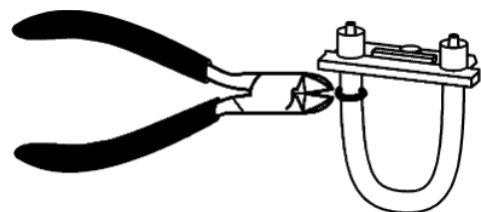

7

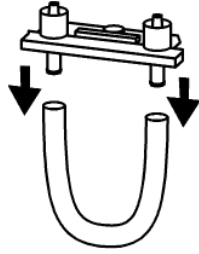

8

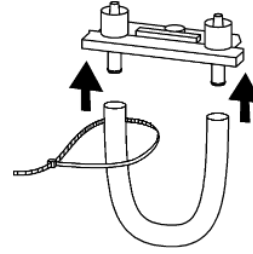

9

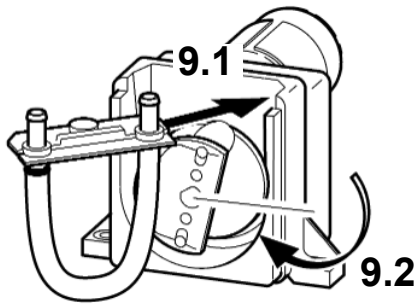

10

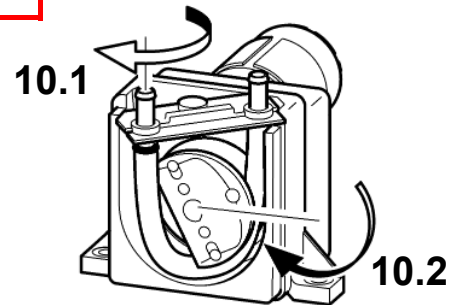

11

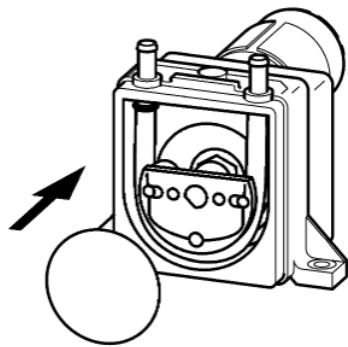

12

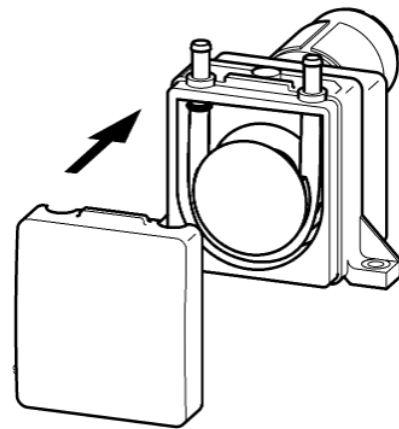

13



14.

6 - 10

16. Kippschalter wechseln

EN Replace the toggle switch

NL Tuimelschakelaar vervangen

CS Výměna kolébkového přepínače

FR Remplacement de l'interrupteur à bascule

PL Wymiana łącznika dźwigienkowego

FI Vipukytkimen vaihto

ES Cambio del conmutador basculante

SV Byta vippbrytare

RU Замена перекидного выключателя

IT Sostituzione dell'interruttore a levetta



8mm



1



10.

2 - **5**

2

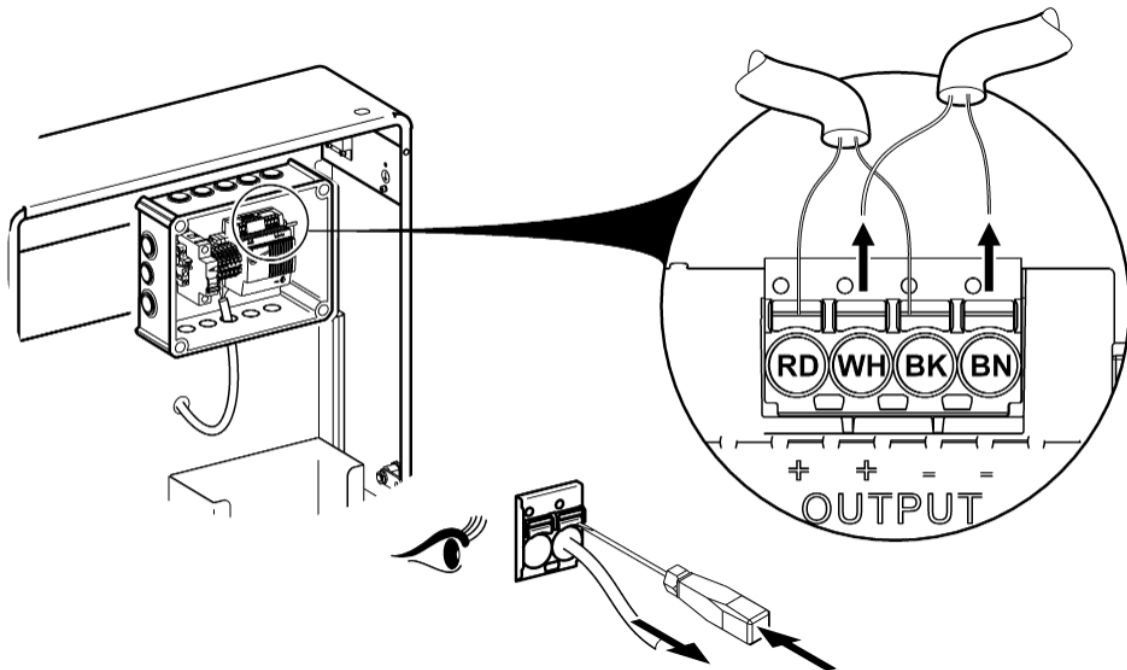

3

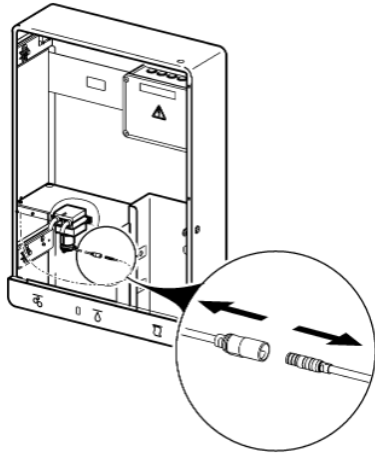

4

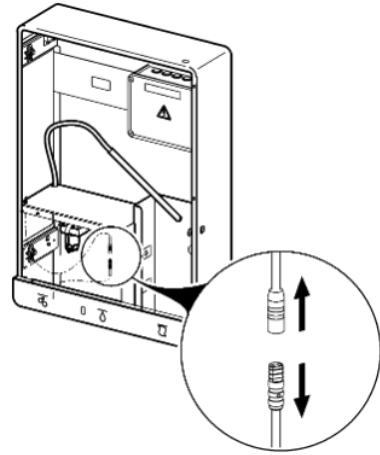

5

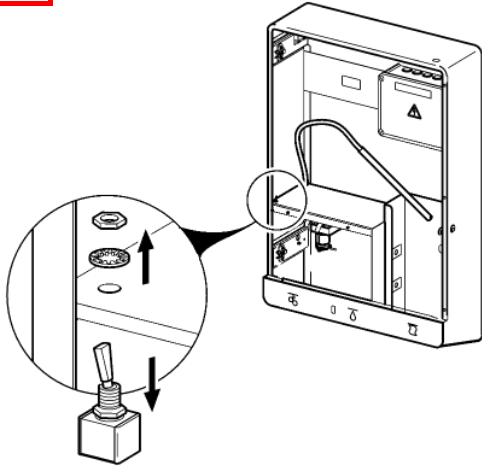

6

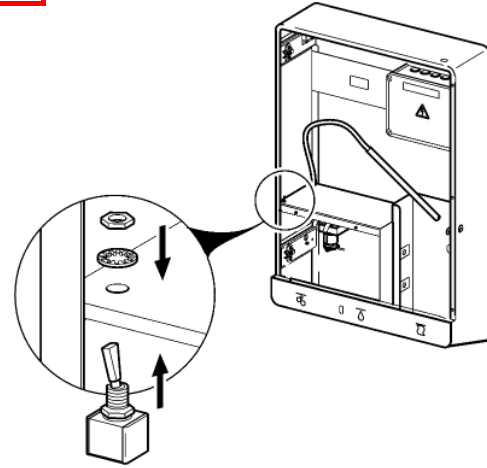

7

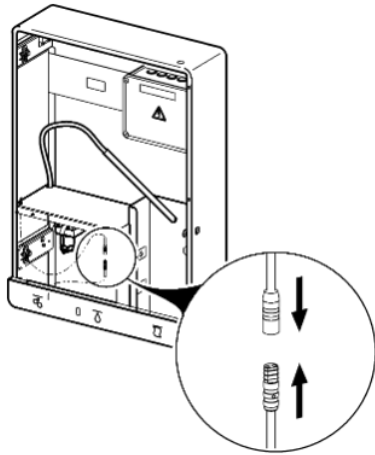

8

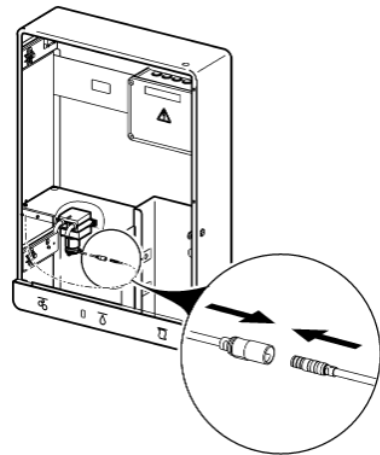

11

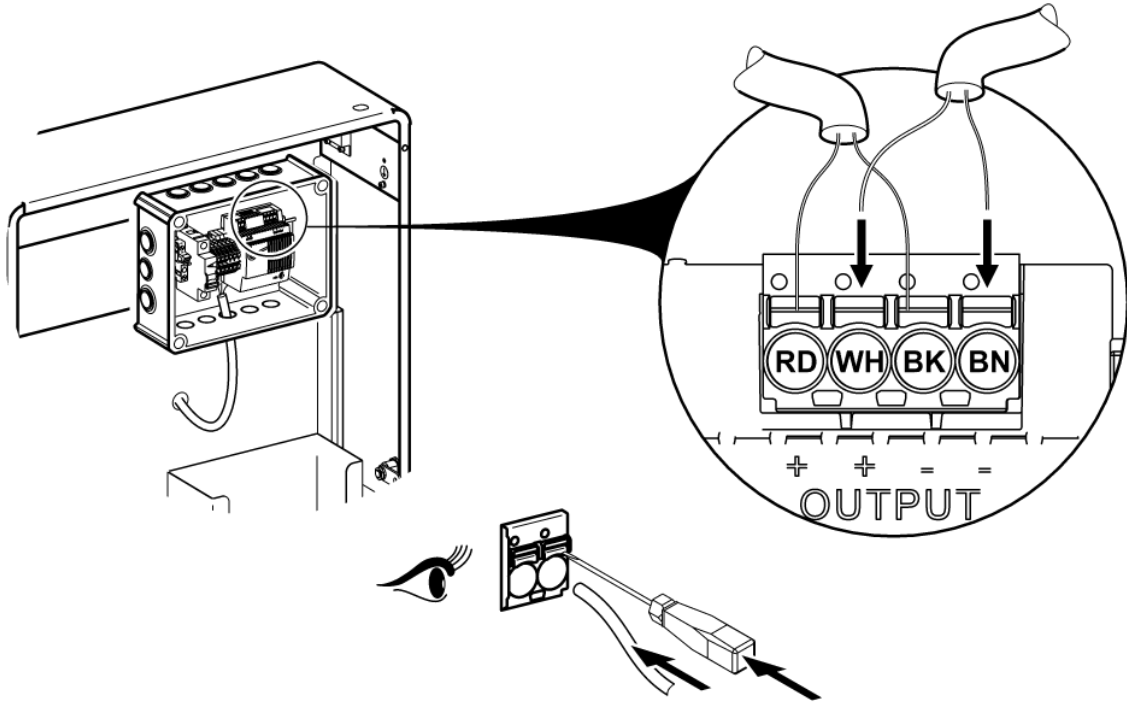

12

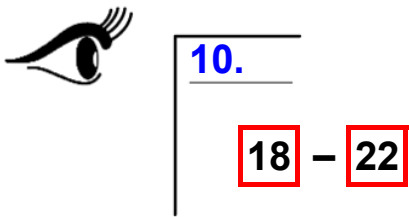

17. Netzteil wechseln

EN Replace the power supply unit
FR Remplacement du bloc
d'alimentation
ES Cambio de la fuente de
alimentación
IT Sostituzione dell'alimentatore

NL Netadapter vervangen
PL Wymiana zasilacza

SV Byta nätdel

CS Výměna síťového zdroje
FI Verkko-osan vaihto

RU Замена блока питания



10 mm



3 mm

1



10.

2 - 3

2

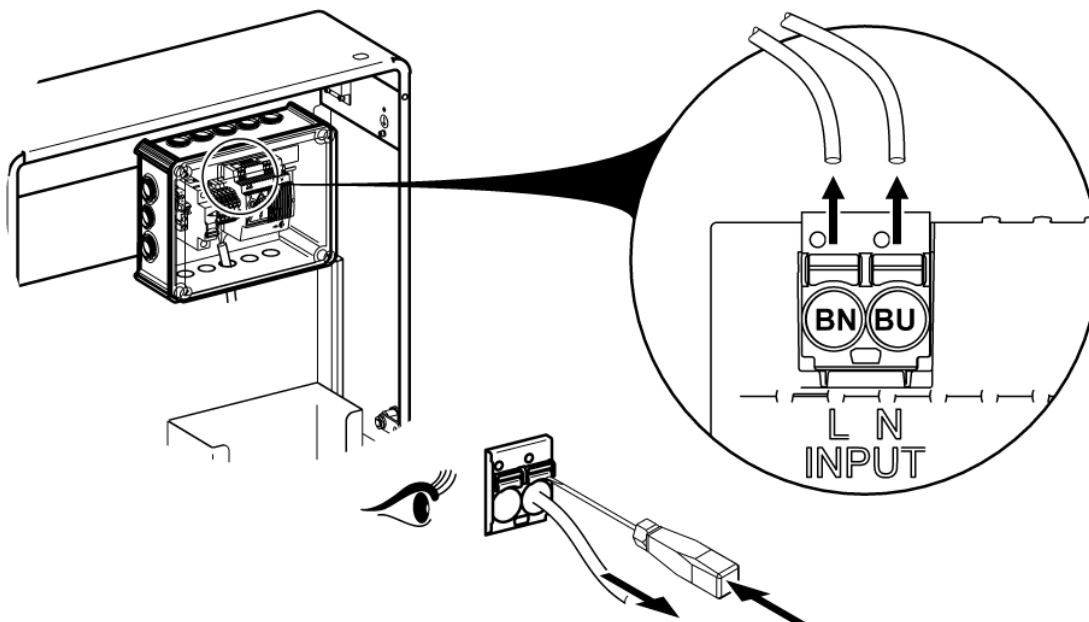

3

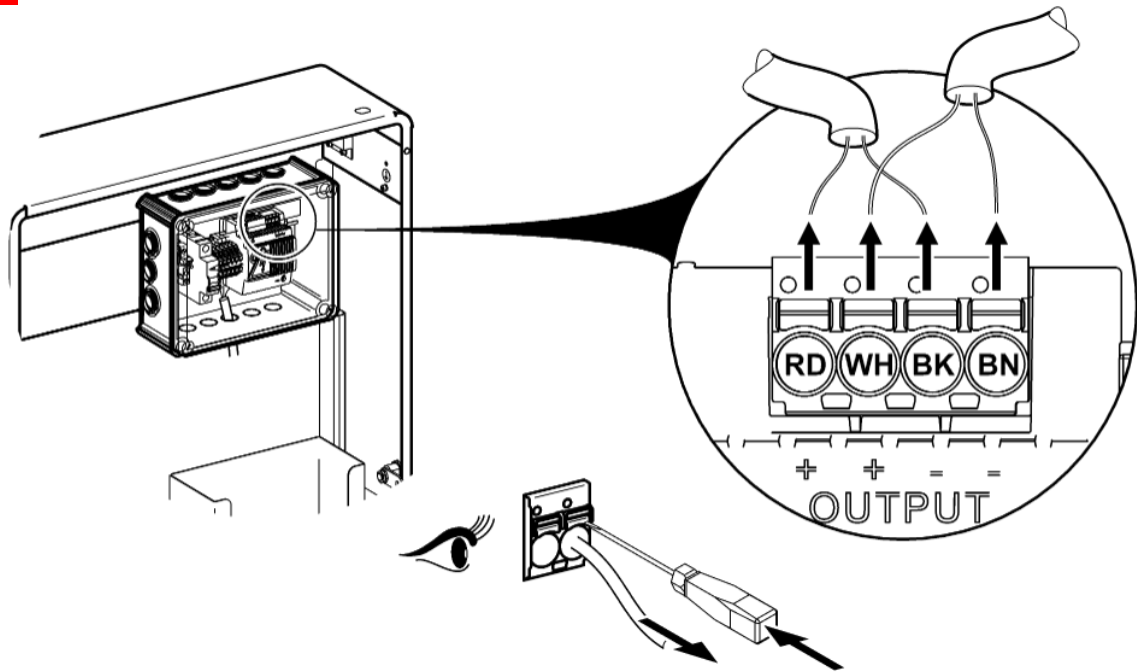

4

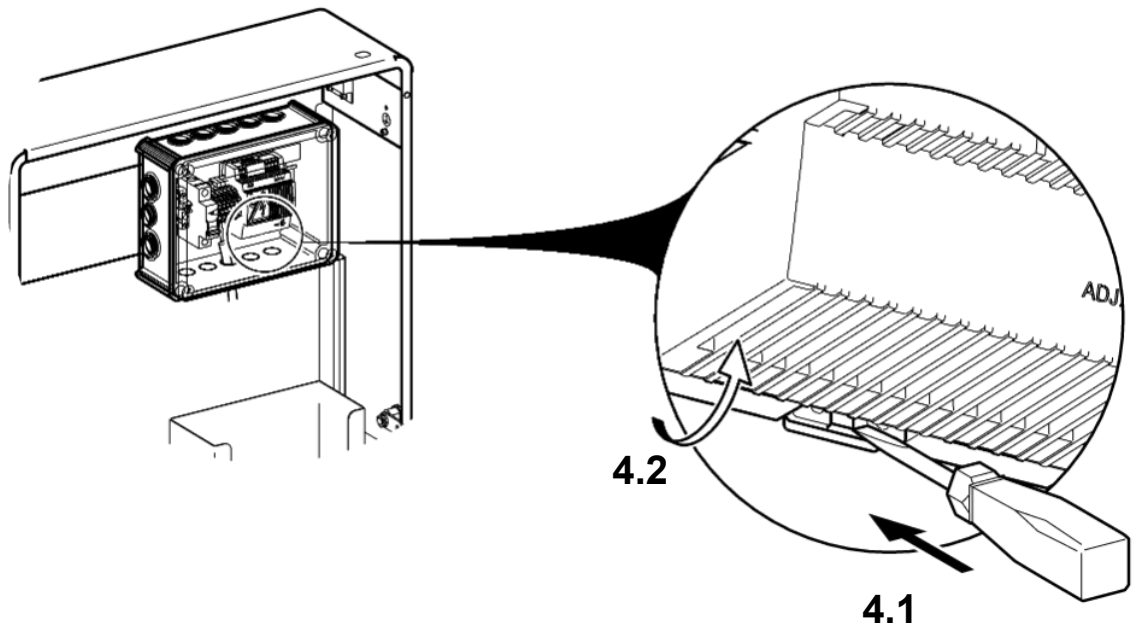

5

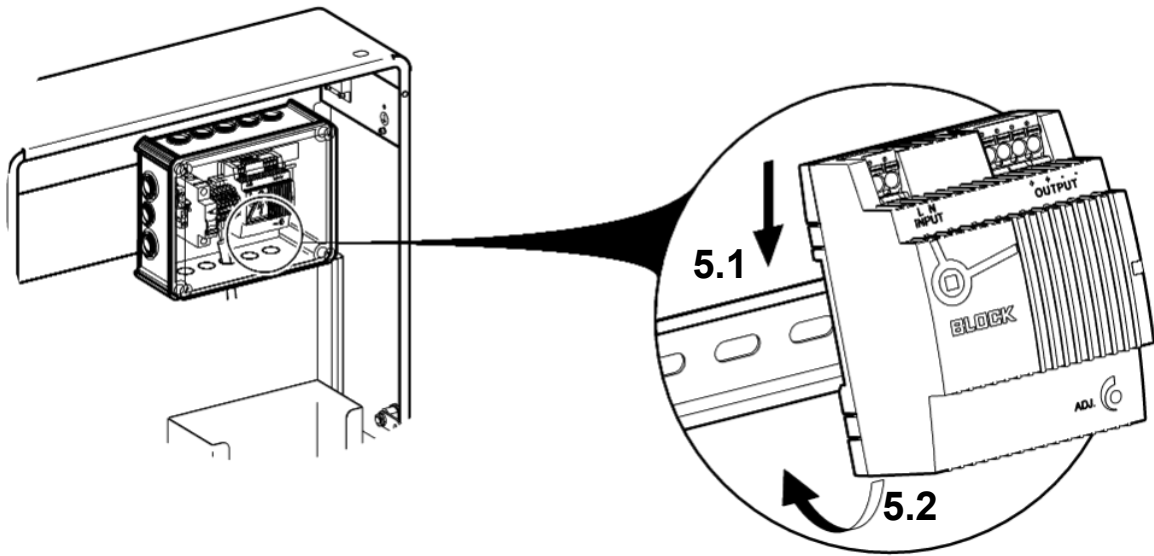

6

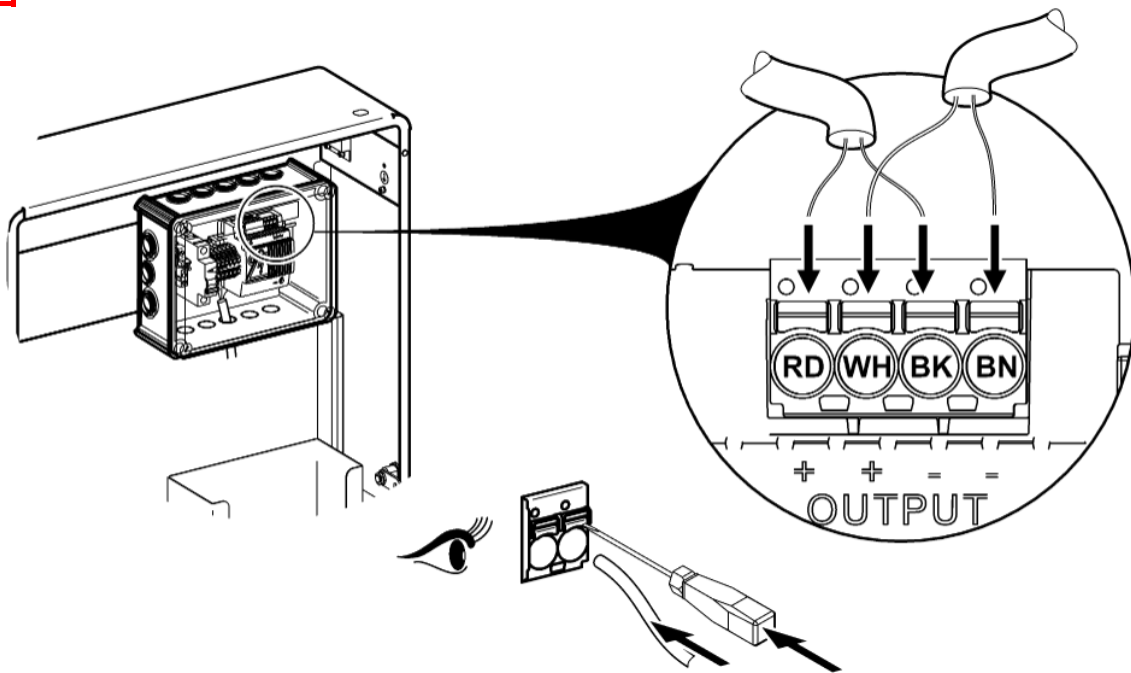

7

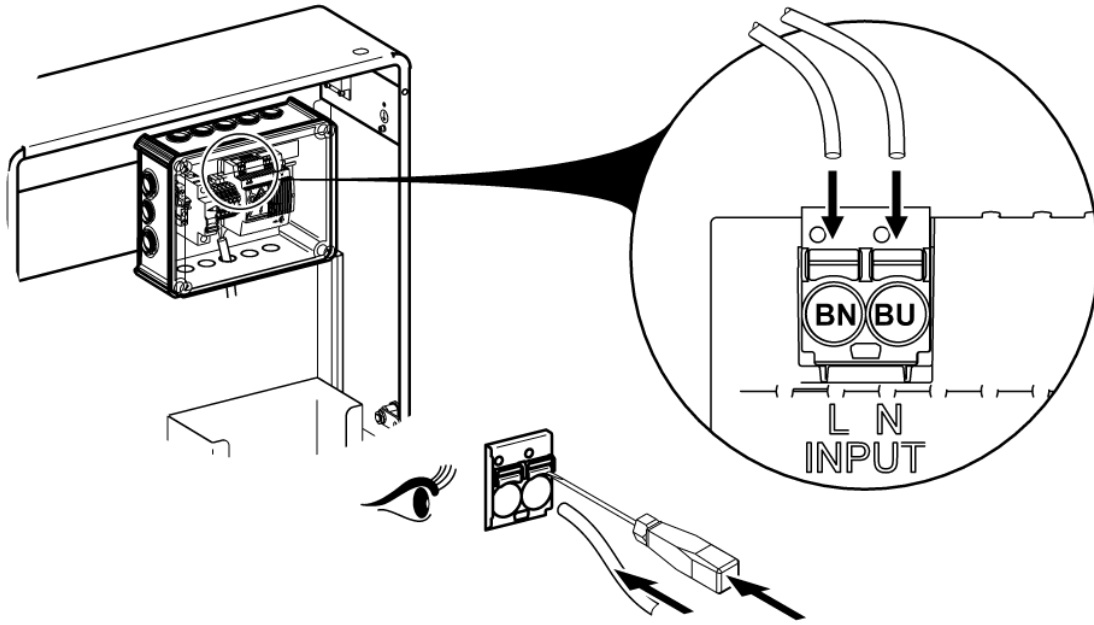

8



10.

21 - 22

18. Iconleiste wechseln

EN Replace the icon bar	NL Pictogrammenbalk vervangen	CS Výměna panelu s ikonami
FR Remplacement de la barre d'icônes	PL Wymiana listwy symboli	FI Kuvakelistan vaihto
ES Cambio de la barra de iconos	SV Byta symbolfält	RU Замена панели пиктограмм
IT Sostituzione della barra delle icone		

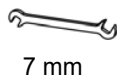

7 mm

1



10.

2 - **6**

2



10.

17 - **22**

19. LED Sensoren wechseln

EN Replace the LED sensors	NL Ledsensoren vervangen	CS Výměna LED senzorů
FR Remplacement des capteurs à LED	PL Wymiana czujników diod LED	FI LED-anturien vaihto
ES Cambio de los sensores LED	SV Byta LED för sensorer	RU Замена светодиода датчиков
IT Sostituzione del LED sensori		



7 mm

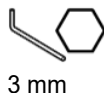

3 mm

1



10.

2 - **6**

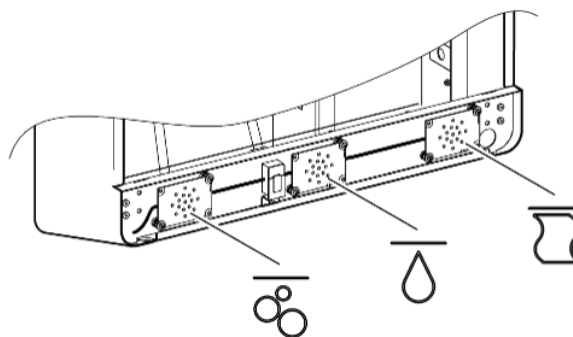

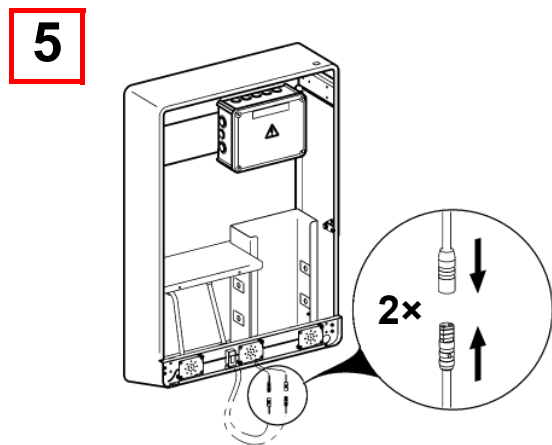
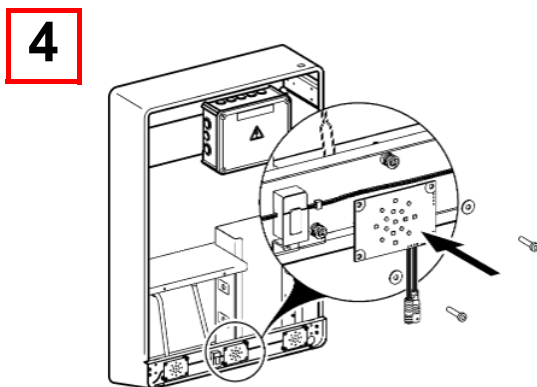
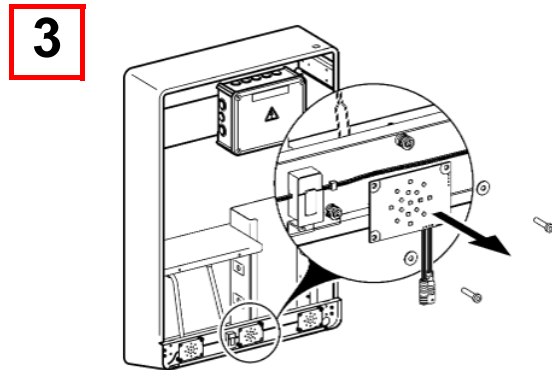
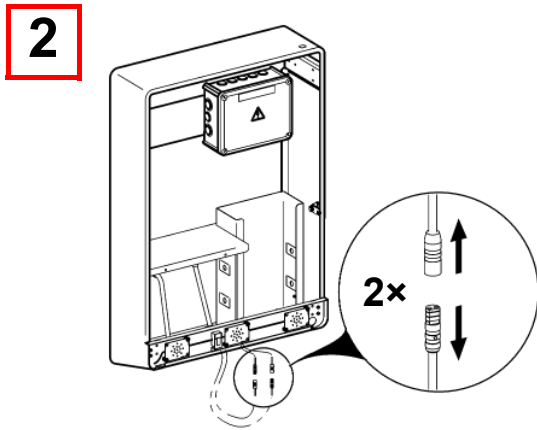

6



10.

17 - **22**

20. LED Waschtisch wechseln

EN Replace the LED washbasin
FR Remplacement du lavabo à LED
ES Cambio del LED lavabo
IT Sostituzione del LED lavello

NL Ledwasbak vervangen
PL Wymiana diod LED szafki
SV Byta LED för tvättställ

CS Výměna LED umyvadla
FI Pesualtaan LEDien vaihto
RU Замена светодиода умывальника



7 mm

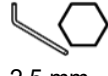

2,5 mm

1



10.

2 - **7**

2

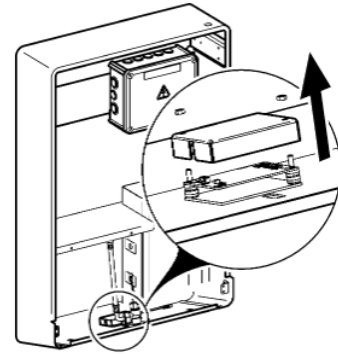

3

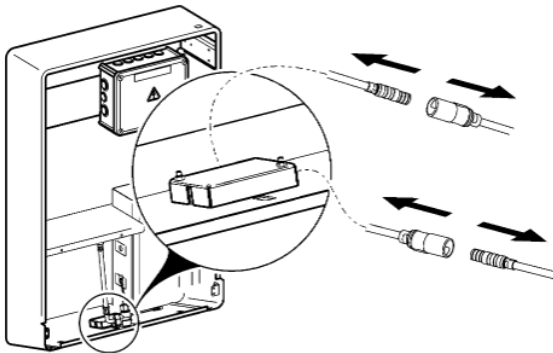

4

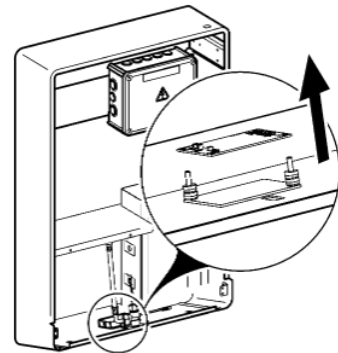

5

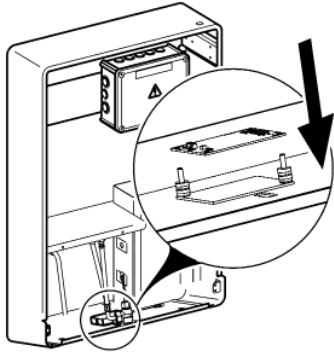

6

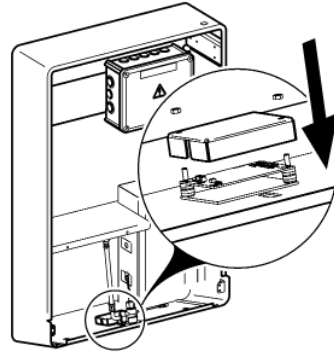

7

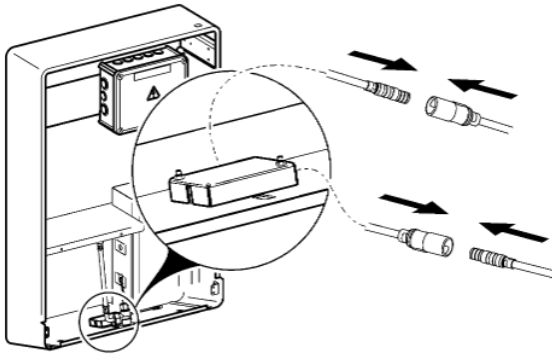

8



10.

16

22

21. Erkennungssensor wechseln

EN Replace the detection sensor	NL Herkenningssensor vervangen	CS Výměna detekčního senzoru
FR Remplacement du capteur de reconnaissance	PL Wymiana czujnika detekcyjnego	FI Tunnistusanturin vaihto
ES Cambio del sensor de detección	SV Byta registreringssensor	RU Замена воспринимающего элемента
IT Sostituzione del sensore di rilevamento		

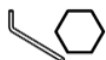

2,5 mm

1



10.

2 - **6**

2

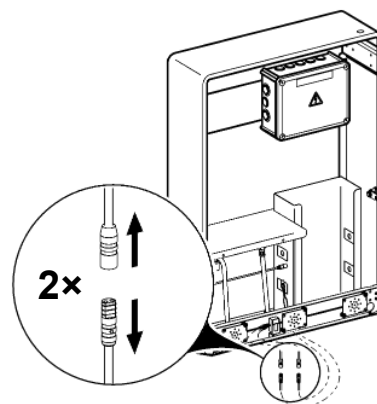

3

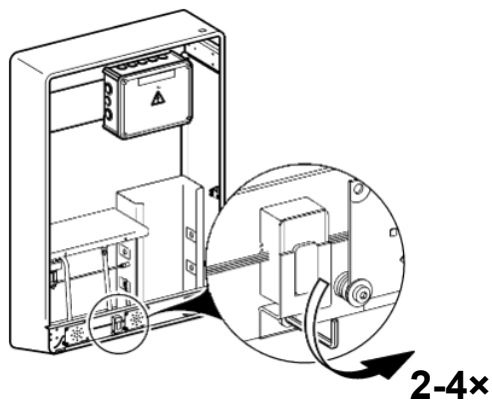

4

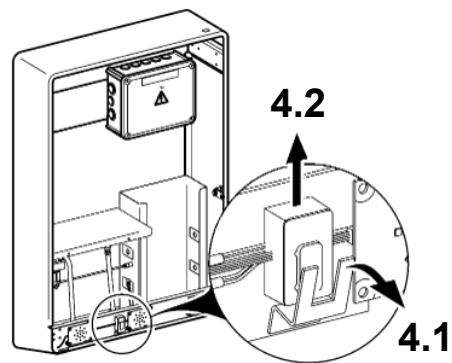

5

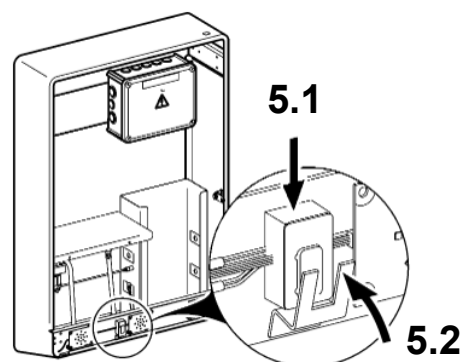

6

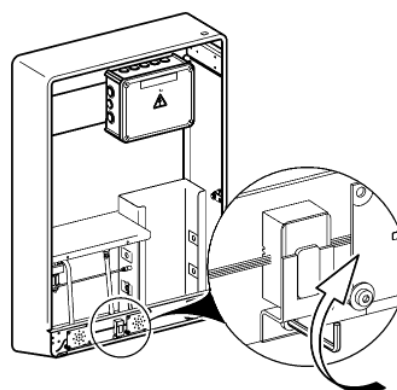

7

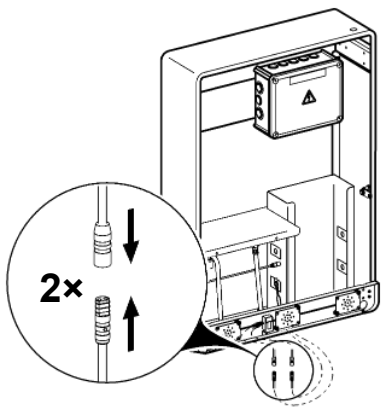

8



10.

17 - 22

22. Sensor wechseln

EN Replace the sensor

FR Remplacement du capteur

ES Cambio del sensor

IT Sostituzione del sensore

NL Sensor vervangen

PL Wymiana czujnika

SV Byta sensor

CS Výměna senzoru

FI Anturin vaihto

RU Замена датчика

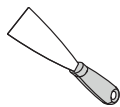

1



10.

2 - 7

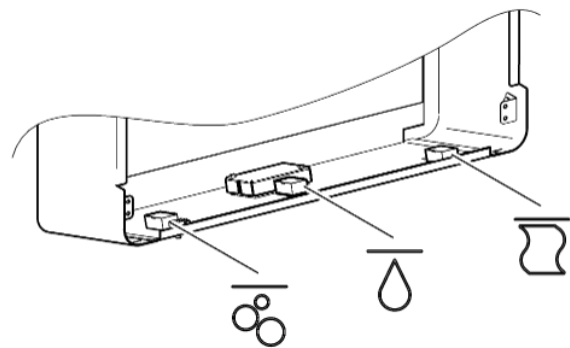

2

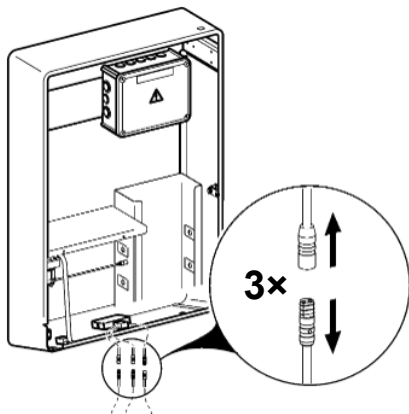

3

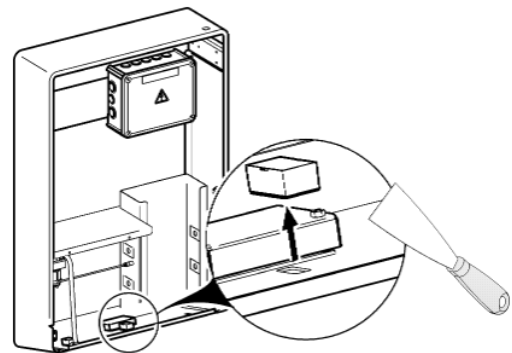

4

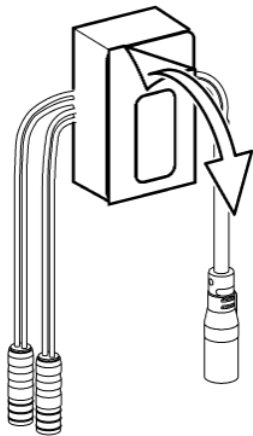

5

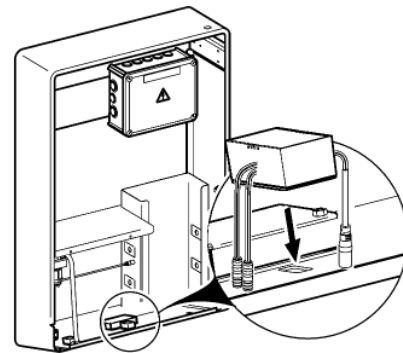

6

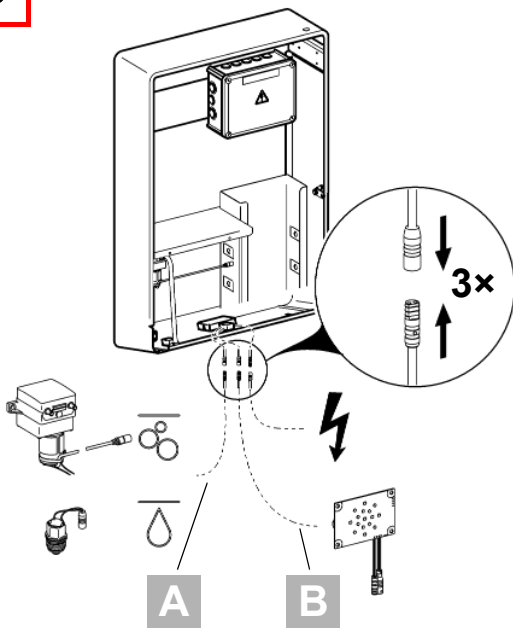

EN A: Black
B: Red

PL A: Czarny
B: Czerwony

DE A: Schwarz
B: Rot

SV A: Svart
B: Röd

FR A: Noir
B: Rouge

CS A: černá
B: Červený

ES A: Negro
B: Rojo

FI A: Musta
B: Punainen

IT A: Nero
B: Rosso

RU A: черный
B: красный

NL A: Zwart
B: Rood

7



10.

16 - 22

23. Magnetventilkartusche wechseln

EN Replacing the solenoid valve cartridge

NL Magneetventielpatroon verandering

CS Výměna kartuše s magnetickým ventilem

FR Remplacement de la cartouche d'électrovanne

PL Wymiana wkładu zaworu elektromagnetycznego

FI Magneettiventtiilipanoksen vaihtaminen

ES Cambiar cartucho de la válvula electromagnética

SV Byta magnetventilpatron

RU Замена картриджа электромагнитного клапана

IT Sostituzione della cartuccia della valvola elettromagnetica



23 mm

1



10.

2 - **7**

2

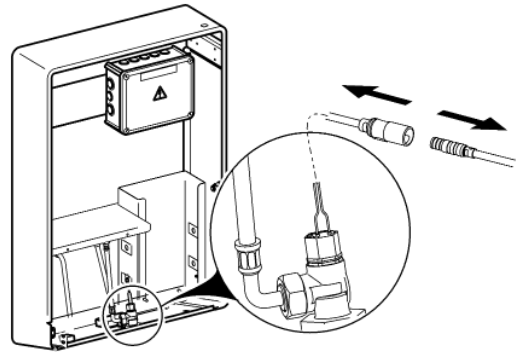

3

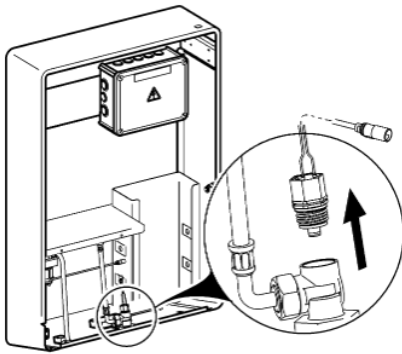

4

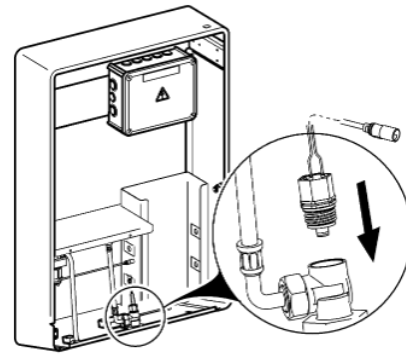

5

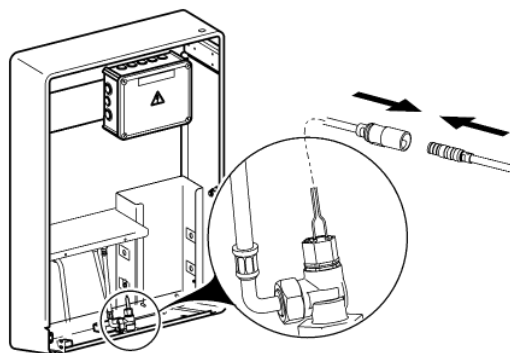

6



10.

16 - **22**

24. Ersatzteile I

EN Replacement parts I
 FR Pièces de rechange I
 ES Piezas de recambio I
 IT Pezzi di ricambio I

NL Reserveonderdelen I
 PL Części zamienne I
 SV Reservdelar I

CS Náhradní díly I
 FI Varaosat I
 RU Запчасти I

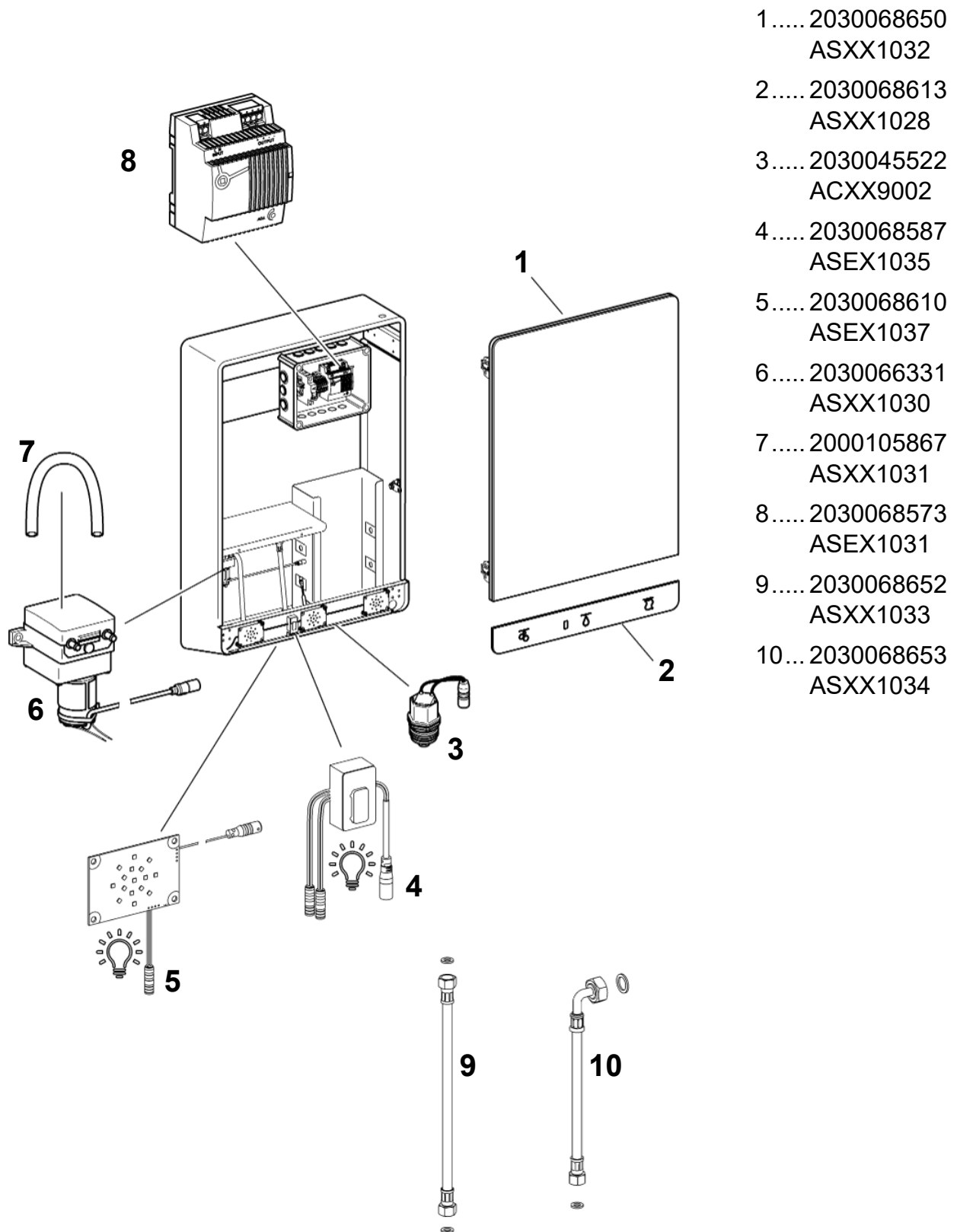

25. Ersatzteile II

EN Replacement parts II
 FR Pièces de rechange II
 ES Piezas de recambio II
 IT Pezzi di ricambio II

NL Reserveonderdelen II
 PL Części zamienne II
 SV Reservdelar II

CS Náhradní díly II
 FI Varaosat II
 RU Запчасти II

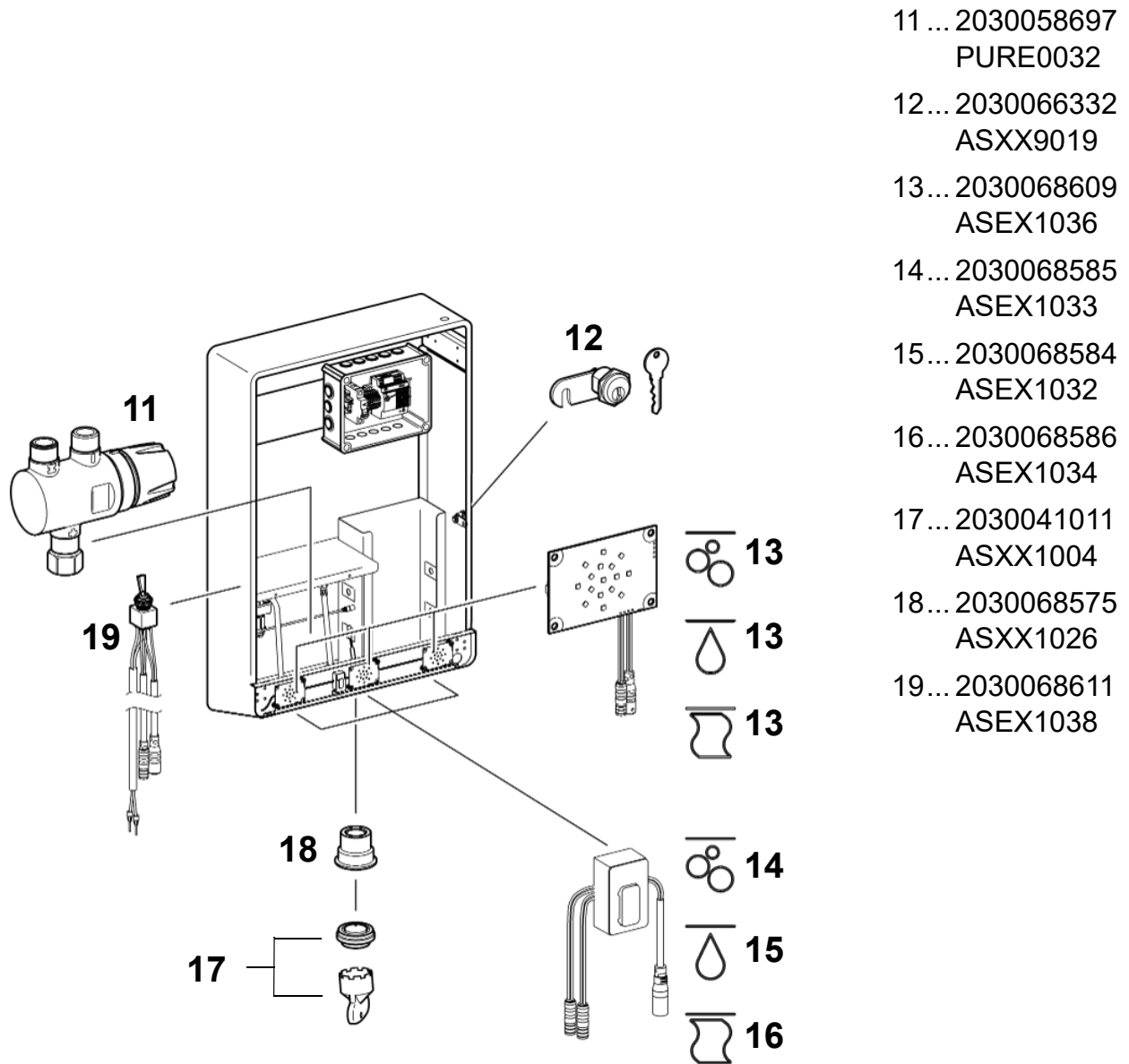

- 11 ... 2030058697
PURE0032
- 12... 2030066332
ASXX9019
- 13... 2030068609
ASEX1036
- 14... 2030068585
ASEX1033
- 15... 2030068584
ASEX1032
- 16... 2030068586
ASEX1034
- 17... 2030041011
ASXX1004
- 18... 2030068575
ASXX1026
- 19... 2030068611
ASEX1038

26. Zubehör

EN Accessories
FR Accessoire
ES Accesorios
IT Accessori

NL Toebehoren
PL Akcesoria
SV Tillbehör

CS Příslušenství
FI Lisävarusteet
RU принадлежности

1

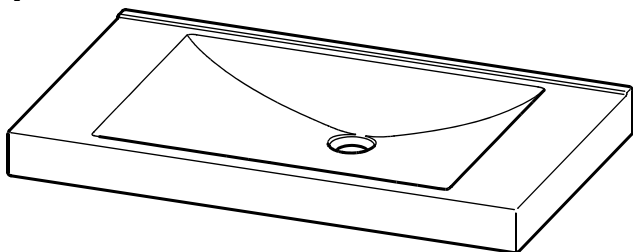

1 2030058091
ANMW0036

2 2030036654
ACEX9005

3 2030036849
ACEX9004

4 2030067925
ZACCS0001

2

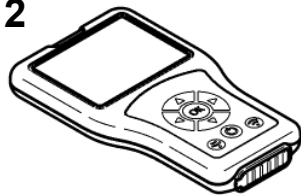

3



4

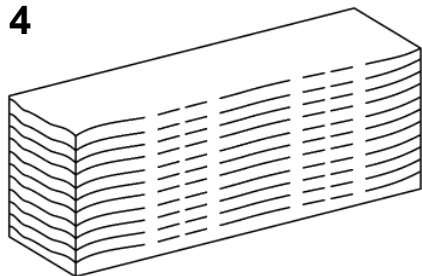

Notizen

EN Notes

FR Notes

ES Notas

IT Annotazioni

NL Notities

PL Uwagi

SV Notiser

CS Poznámky

FI Muistiinpanot

RU Примечания

Notizen

EN Notes

FR Notes

ES Notas

IT Annotazioni

NL Notities

PL Uwagi

SV Notiser

CS Poznámky

FI Muistiinpanot

RU Примечания

Notizen

EN Notes

FR Notes

ES Notas

IT Annotazioni

NL Notities

PL Uwagi

SV Notiser

CS Poznámky

FI Muistiinpanot

RU Примечания

Australia

PR Kitchen and
Water Systems Pty Ltd
Dandenong South VIC 3175
Phone +61 3 9700 9100

Austria

KWC Austria GmbH
6971 Hard
Phone +43 5574 6735 0

**Belgium, Netherlands &
Luxembourg**

KWC Aquarotter GmbH
9320 Aalst; Belgium
Phone +31 (0) 492 728 224

Czech Republic

KWC Aquarotter GmbH
14974 Ludwigsfelde, Germany
Phone +420 281 090 429

France

KWC Austria GmbH
6971 Hard
Phone +33 800 909 216

Germany

KWC Aquarotter GmbH
14974 Ludwigsfelde
Phone +49 3378 818 0

Italy

KWC Group AG
5726 Unterkulm, Switzerland
Numero Verde 800 789 233

Middle East

KWC ME LLC Ras Al Khaimah,
United Arab Emirates
Phone +971 7 2034 700

Poland

KWC Aquarotter GmbH
14974 Ludwigsfelde, Germany
Phone +48 58 35 19 700

**South Africa &
Sub Saharan Africa**

Franke South Africa
4052 Durban
Phone +27 31 450 63 00

Spain

KWC Austria GmbH
6971 Hard, Austria
Phone +43 5574 6735 211

Switzerland & Liechtenstein

KWC Group AG
5726 Unterkulm, Switzerland
Phone +41 62 768 69 00

Turkey

KWC ME LLC Ras Al Khaimah,
United Arab Emirates
Phone +971 7 2034 700

United Kingdom

KWC DVS Ltd - Northern Office
Barlborough S43 4PZ
Phone +44 1246 450 255

KWC DVS Ltd - Southern Office
Paignton TQ4 7TW
Phone +44 1803 529 021

EAST EUROPE

Bosnia Herzegovina
Bulgaria | Croatia
Hungary | Latvia
Lithuania | Romania
Russia | Serbia | Slovakia
Slovenia | Ukraine

KWC Aquarotter GmbH
14974 Ludwigsfelde, Germany
Phone +49 3378 818 261

SCANDINAVIA & ESTONIA

Finland | Sweden | Norway
Denmark | Estonia

KWC Nordics Oy
76850 Naarajärvi, Finland
Phone +358 15 34 111

OTHER COUNTRIES

KWC Austria GmbH
6971 Hard, Austria
Phone +43 5574 6735 0

